

# **PowerMate**®

**Stair Climbing Hand Trucks & LiftGates**

## **LiftGate™ LV-SERIES TL**

Installation & Operation Manual

Download: [www.powermate.info/t20/powermate\\_manual\\_lv](http://www.powermate.info/t20/powermate_manual_lv)



## TABLE OF CONTENTS

<b>Section 1 - General</b>	
Warning Page.....	1.01
PowerMate LiftGate Description.....	1.02
Delivery and Warranty Registration.....	1.02
<b>Section 2 - Safety</b>	
Hazard Graphical Symbols.....	2.01
LiftGate Mandatory Decals.....	2.02
Mandatory Safety Decal Placement.....	2.04
Safety Precautions.....	2.05
Fastener Torque Requirements.....	2.06
<b>Section 3 - Instructions</b>	
LiftGate Operating Instruction.....	3.01
Loading Instruction for 360 Lb. LiftGate.....	3.02
Installation Dimensional Requirements.....	3.03
Installation Kit.....	3.04
Additional Items and Tools.....	3.05
Determining Installation Location.....	3.06
Base Hole Locations.....	3.07
Installing the LiftGate Unit.....	3.08
Running the Wires.....	3.09
<b>Section 4 - LV-Series PowerMate Components</b>	
Inner Frame Assembly.....	4.01
Outer Frame Assembly.....	4.02
Inner/Outer Frame Assembly.....	4.03
Inner/Outer Frame – Swing Arm Assembly.....	4.04
Final Assembly LV-7.....	4.05
Control Box Assembly.....	4.06
Screw Assembly LV-7.....	4.07
Brake Assembly Kit.....	4.08
Bearing Override Kit.....	4.09
<b>Section 5 - Maintenance</b>	
Maintaining the PowerMate LiftGate.....	5.01
Screw Assembly Removal.....	5.02
Brake Assembly Replacement.....	5.03
Override Bearing Assembly Procedure.....	5.03
Drive Screw Removal/Installation Instruction.....	5.03
Screw Assembly Installation.....	5.04
Drive Screw Removal/Installation Drawing.....	5.05
Motor Removal and Installation Instruction.....	5.07
Ballnut Removal and Replacement.....	5.08
Retract Stroke Adjustment.....	5.09
Roller Replacement.....	5.10
Back Bar Assembly.....	5.11
LV-Series Wiring Diagram.....	5.12
Actuator Manual Retraction.....	5.13
<b>Section 6 - Specifications</b>	
PowerMate LiftGate Specifications.....	6.01
Solidstate Controller Specifications.....	6.02
<b>Section 7 - Accessory Installations</b>	
Back Bar Installation.....	7.01
<b>Section 8 - Accessories</b>	
LG/V-3 LiftGate Features.....	8.01
LG/V-6 LiftGate Features.....	8.02
Warranty.....	8.03
Declaration of Conformity.....	8.04
Daily Maintenance Schedule.....	8.05



# WARNING

**Failure to obey the Instructions and Safety rules in this manual could result in death or serious injury.**

**Read the Operating Manual completely. Only competent, trained operators may use this equipment. Training is essential to understanding all the features and capabilities of your PowerMate, and ensure good safe work practices.**

Training courses are available through  
L P INTERNATIONAL INC., please call  
1-800-697-6283



# ATTENTION!

The photographs, diagrams and illustrations in this manual are of the LG-6 Right-hand unit installation in a box truck. Use this manual as a guideline when installing Left-hand units and/or other LG/LV-Series units in alternative locations in other vehicle types.

## PowerMate® LiftGate™

In choosing to buy a **PowerMate®**, you will find that it will help your business in more ways than you can imagine. Not only is it a revenue generator, **PowerMate®** is also a labour saver and a great promotional tool to help you expand your business in the commercial and industrial markets.

The **PowerMate® LiftGate™** provides a safe and easy way for moving and delivering heavy and awkward loads in and out of your vehicle at the push of a button.

We at L P INTERNATIONAL INC. look forward to continuing our mission to help you realize your full profit potential of having a **PowerMate® LiftGate™** in your Profit Center.

For more information on the complete **PowerMate®** product line, please call toll free 1-800-697-6283.

### **DELIVERY AND WARRANTY REGISTRATION**

Upon receipt of your **LiftGate™** unit, examine the unit to determine if it has been damaged in transit. Examine the unit for mishandling, paying particular attention to the control box and switches, the limit switch assembly and the exposed wire looms.

If required, make note of any deficiencies on the Delivery Acceptance Form. Registering your unit for the Warranty can be done online at [www.powermate.info](http://www.powermate.info). Click on Service, fill in the required fields under Warranty and click Send Now.

When ordering parts, or requesting information or service on the unit, please refer to the model and serial number. The model number can be found on the data decal on the top of the control box. The serial number can be found stamped to the top corner of the aluminum outer frame.



**WARNING** The use of this equipment with any options other than those specified in this manual may create a hazard.

#### **Manufactured By:**

L P INTERNATIONAL INC.  
P.O. Box 696, 151 Savannah Oaks Drive  
Brantford, Ontario, Canada N3T 5P9  
TEL: (519) 759-3292 FAX: (519) 759-3298

**1-800-697-6283**



## HAZARD GRAPHICAL SYMBOLS

The **PowerMate**® products use graphical symbols, safety colours, and signal words throughout the Operators Manual and on the units themselves. Operators using the **PowerMate**® must familiarize themselves with these symbols.



**Safety Alert Symbol:** This symbol indicates a potential personal injury hazard. Safety information following this symbol must be followed to avoid possible injury or death.



**DANGER:** Indicates an *imminently* hazardous situation which, if not avoided, will result in death or serious injury.



**WARNING:** Indicates a *potentially* hazardous situation which, if not avoided, could result in death or serious injury.



**CAUTION:** Indicates a potentially hazardous situation which, if not avoided, may result in minor or moderate injury.



**NOTICE:** The signal word to address practices not related to personal injury.

### SAFETY LABEL MAINTENANCE

Safety of the operator and surrounding environment must be considered at all times. To that end, safety labelling on the **PowerMate**® must be maintained to provide legible safety information. Clean the labels with soap and water. Do not use solvent-based cleaners because they may damage the labels. Replace damaged or missing labels. Replacement labels may be purchased from L P International Inc. Customer Service Phone number 1-800-697-Mate.

## DANGERS, WARNINGS, AND CAUTIONS

The following decals are mandatory. Refer to the Location of Mandatory Labels Drawing for placement. Replacement decals are available from LP International Inc.



PN 057020A



PN 082650B



PN 057050A



PN 057080A



PN 057010A



PN 057030A

## ADDITIONAL MANDATORY DECALS

The following decals are mandatory. Refer to the Location of Mandatory Labels Drawing for placement. Replacement decals are available from LP International Inc.

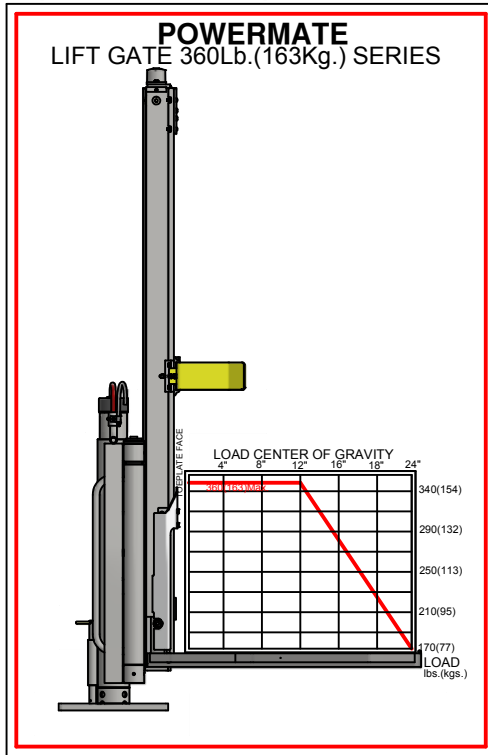

PN 082710C

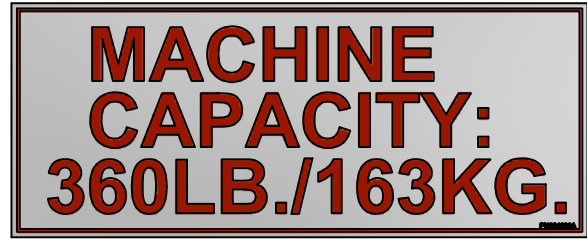

PN 084060A



PN 083890B

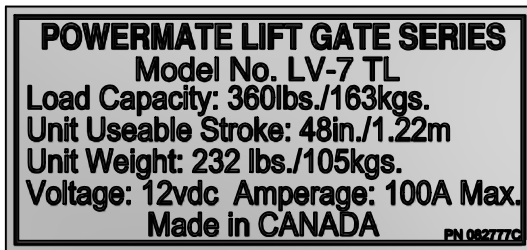

PN 082777C

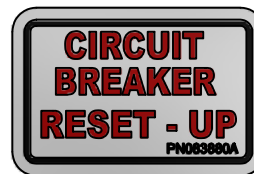

PN 083880A

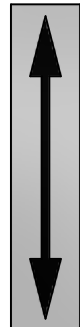

PN 083870A

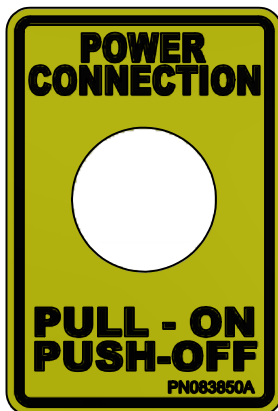

PN 083850A



PN 084020B

PARTS LIST			
ITEM	QTY	PART No.	DESCRIPTION
1	1	057020A	DANGER DECAL - CRUSH HAZARD FOOT
2	1	082650B	DECAL - MOVING PARTS
3	1	057080A	WARNING DECAL - MOVING PARTS Small
4	1	057050A	WARNING DECAL - KEEP OFF
5	1	057010A	DECAL - WARNING AUTHORIZED PERSONNEL
6	1	084060A	DECAL - LOAD CAPACITY 360lb.
7	1	083890B	DECAL-SAFETY INSTRUCTION LG-SERIES 360lb.
8	1	082710C	DECAL - LOADING CHART LV-7 TL
9	1	082777C	DECAL - LV-7 TL SPECIFICATIONS
10	1	084020A	DECAL - MANUAL WEB REFERENCE LV-7
11	1	083870A	DECAL - UP / DOWN ARROW
12	1	083880A	DECAL - CIRCUIT BREAKER RESET
13	1	083850A	DECAL - POWER CONNECTION LV-7
14	1	057030A	DANGER DECAL - ELECTRICAL SHOCK
15	1	057160A	DECAL - FAULT ALERTS

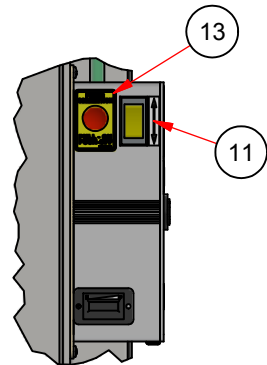
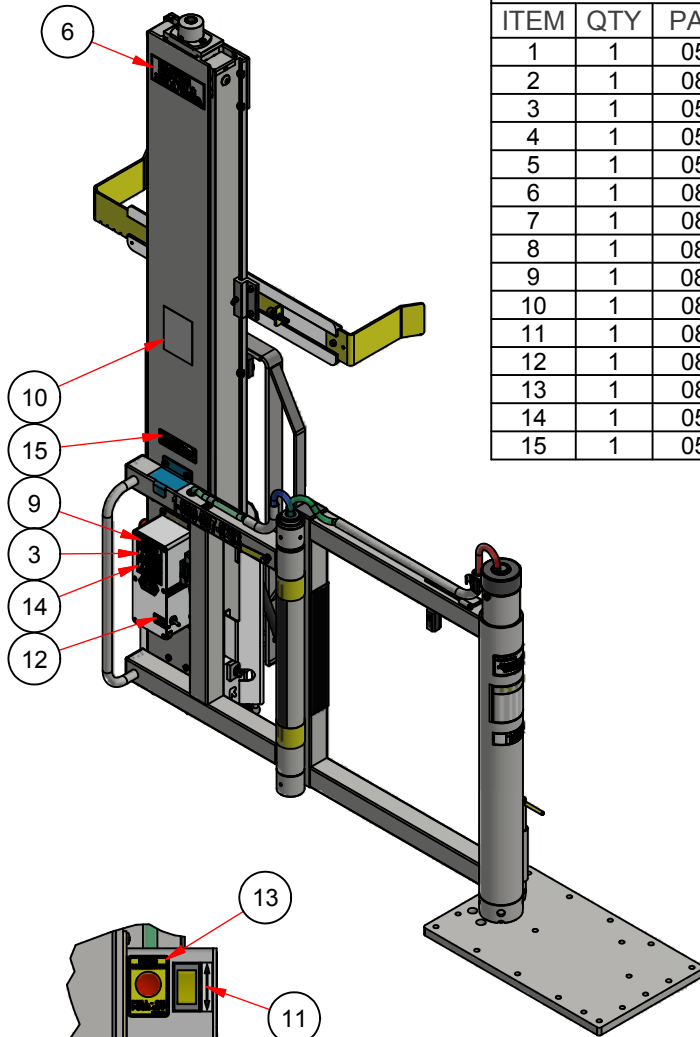

SWITCH SIDE OF CONTROL BOX

**LOCATION OF MANDATORY LABELS FOR 360lb. LV-7 LIFTGATE UNITS**

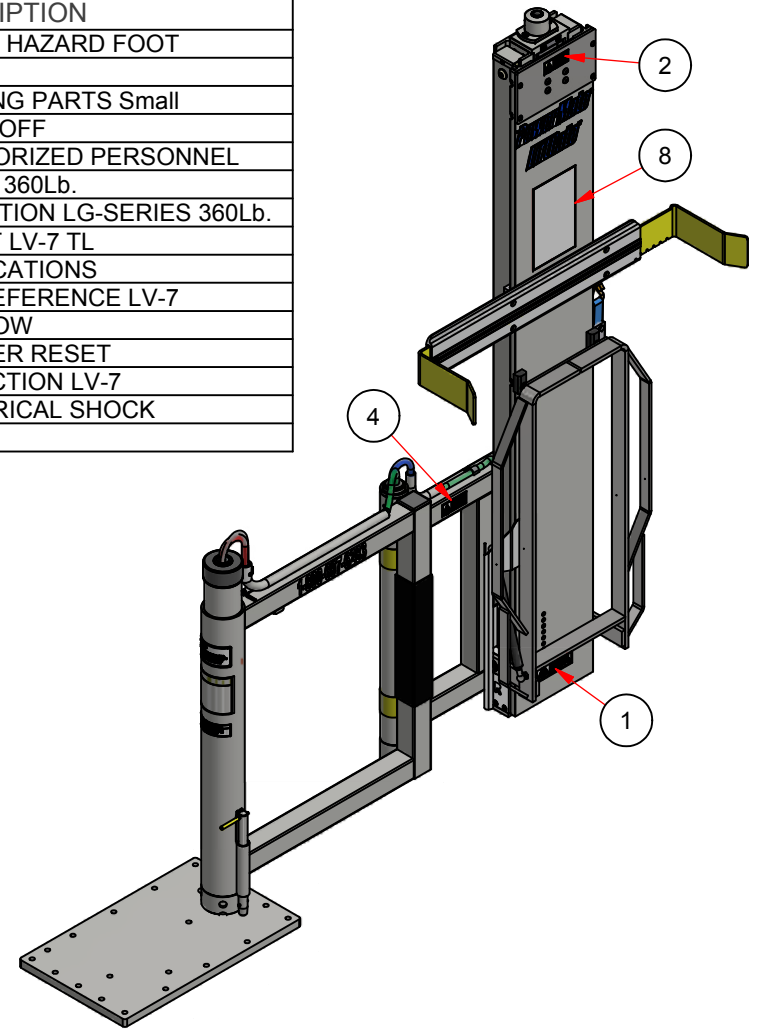
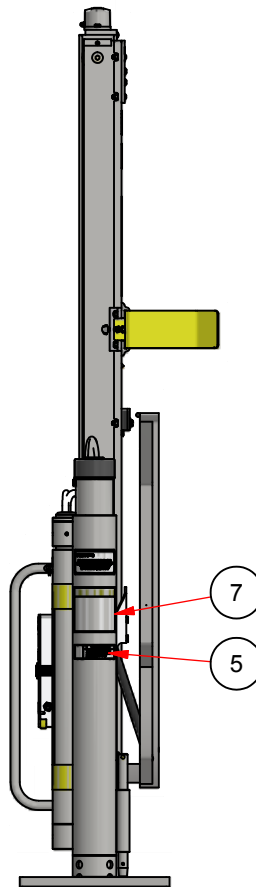

NOTE: Indicated Decals are intended to create awareness in operators, owners, and maintenance personnel, of the potential safety hazards and operational limits. Insure that these decals are in place. Replacements are available from L P International Inc.

## SAFETY PRECAUTIONS

**WARNING:** Read and understand all instructions. Follow the safety rules listed below as well as the other basic safety precautions. Failure to do so may result in serious injury.



### WORK AREA

**CHECK YOUR WORK AREA.** Inspect your work area for obstacles such as holes, debris or rough spots. Look for areas not able to support the load, such as access or drain covers or soft ground. Watch out for liquid spills or slippery surfaces. Be on the alert for anything that might cause you to lose your balance, control or concentration. Insure that the vehicle is level. The LiftGate™ unit should not be activated if the vehicle is on any inclination.

**PLAN YOUR WORK.** Arrange your work to avoid unnecessary steps or effort. Position your vehicle for proper clearance from roadside curbs and obstacles. Insure that the Load Chart is considered when engaging the load to be transferred. Do not overload the PowerMate.

**KEEP YOUR WORK AREA CLEAR.** All visitors should be kept away from the work area.

### PERSONAL SAFETY

**STAY ALERT.** Always focus your attention in the direction of travel. Always maintain proper footing and balance. Constantly check for clearance above, below and on all sides. When loading onto or off of a vehicle, be prepared for movement in the vehicle suspension system.

**USE COMMON SENSE.** Do not operate equipment when you are tired or injured. Keep both hands positioned on unit at all times. Never play games. Do not ride on the unit. Do not attempt to use the equipment as a jack.

### MAINTAIN THE EQUIPMENT REGULARLY

**DO NOT** operate equipment that is known to be damaged or malfunctioning. Never remove or override any mechanical or electrical safety devices. Poorly maintained equipment jeopardizes the safety of the operator and all other personnel. Remember safety is your responsibility. Complete a daily inspection procedure. Have the equipment thoroughly checked by a competent service person at least once a year.

### SECURE FOR TRANSPORT

When the equipment is not in use, ensure the LiftGate™ and the load are fully secure before moving the vehicle.

# FASTENER TORQUE REQUIREMENTS

Unless otherwise specified in this manual, torque bolts of the following sizes to the torque values indicated.

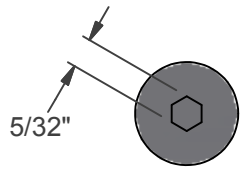

TORQUE TO 125 INCH-POUNDS  
-apply WEICONLOCK AN302-42

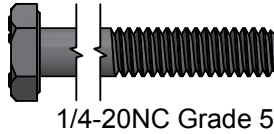
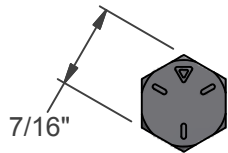

TORQUE TO 92 INCH-POUNDS

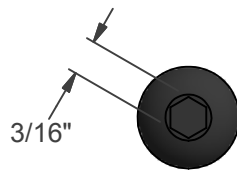

TORQUE TO 16 FOOT-POUNDS  
-apply WEICONLOCK AN302-42

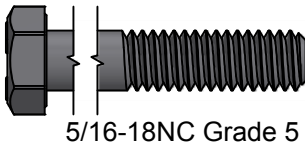
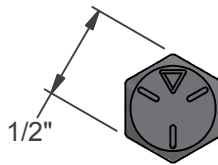

TORQUE TO 16 FOOT-POUNDS  
-apply WEICONLOCK AN302-42

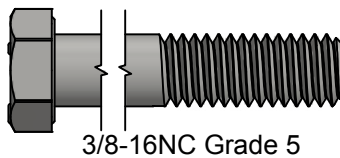
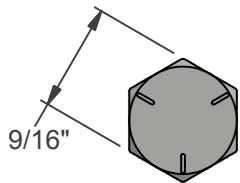

TORQUE TO 26 FOOT-POUNDS

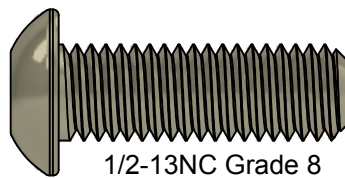
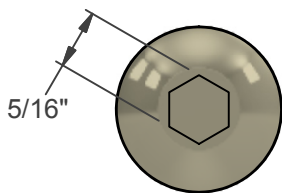

TORQUE TO 64 FOOT-POUNDS  
-apply WEICONLOCK AN302-42

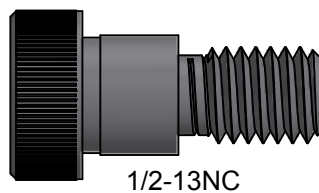
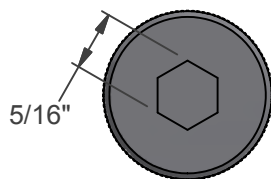

TORQUE TO 34 FOOT-POUNDS  
-apply WEICONLOCK AN302-42



## OPERATING INSTRUCTIONS

**WARNING!** The vehicle must be parked on a level surface prior to operating the LiftGate Unit. Safety shoes must be worn! Read the instructions completely before operating the unit. **DO NOT** exceed Max. Capacity Limit.



1. Refer to the Loading Chart, in this Manual or on the face of the LiftGate Inner Frame, to determine if the load to be lifted will fit in the load capacity envelope of the PowerMate unit.
2. Pull the Power Disconnect Switch to the “ON” position.
3. The Rocker Switch controls the up/down operation of the unit. Depressing the top of the switch will raise the Toeplate Loop and depressing the bottom of the switch will lower the Toeplate Loop. Raise the Toeplate Loop off the surface and dis-engage the Lock Pin, to allow positioning of the unit. Maneuver the Toeplate Loop to the load and lower the Toeplate Loop to the surface. Place load on the Toeplate Loop and ensure the load is engaged with the unit Back Bar if the load is high enough.
4. Raise the load to the desired height. The actuator mechanism will stop automatically when the top stroke limit is reached, at which point the rocker switch should be released.
5. Swing the load to required position using the unit Handle. Use the Lock Pin whenever possible.
6. Lower the load down to the desired surface (vehicle floor or the ground). The down stroke will end automatically when the Toeplate Loop makes contact with any surface. Remove the load.
7. When the operation is complete, park the unit folded in the vehicle. Raise the Toeplate Loop to its vertical position and engage the Hook Strap. Engage the Lock Pin, lower the Toeplate Loop to the floor until the actuator stops (automatic), and depress the Power Disconnect Switch to the Off position.

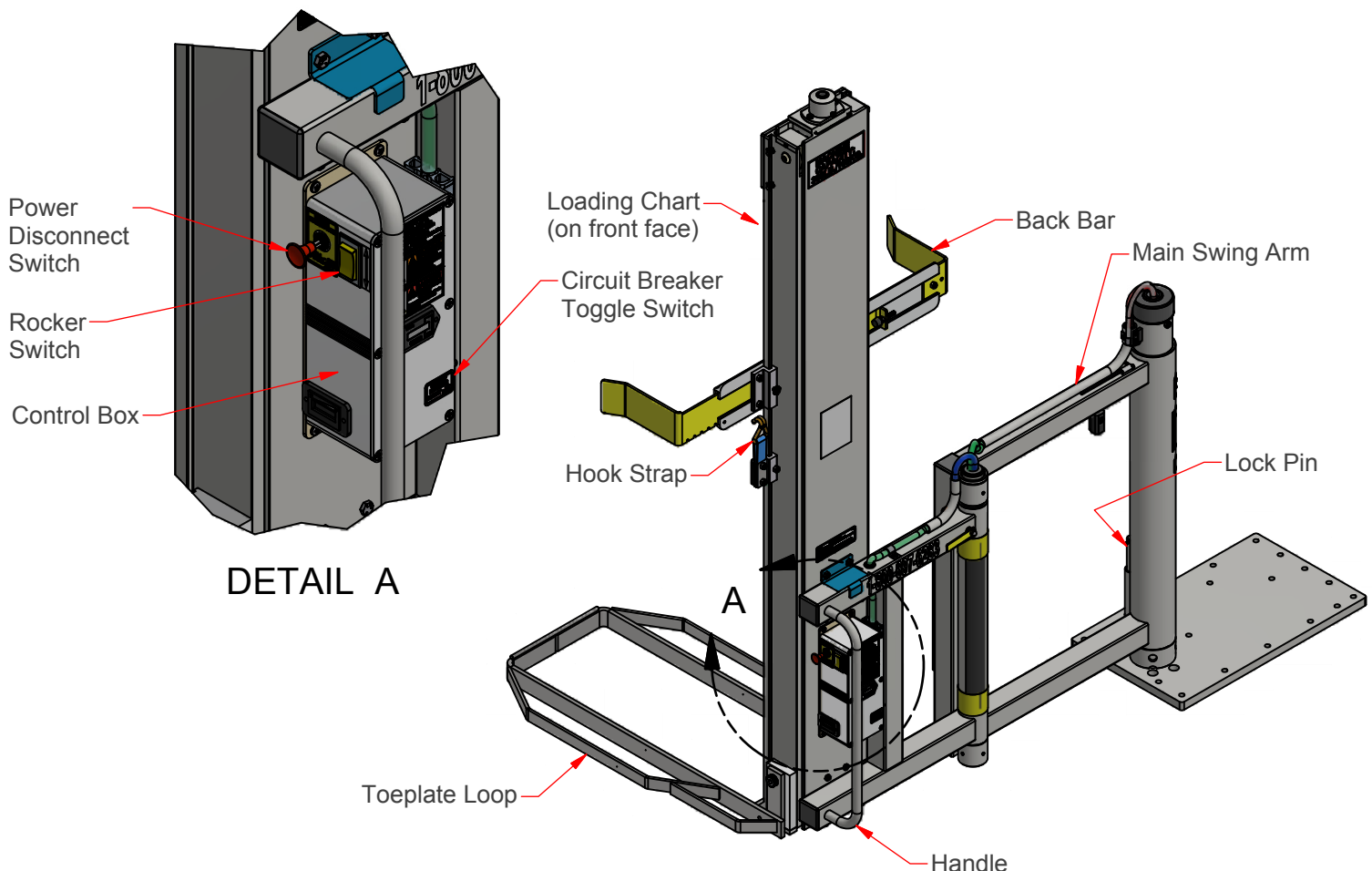

# POWERMATE

## LIFT GATE 360Lb.(163Kg.) SERIES

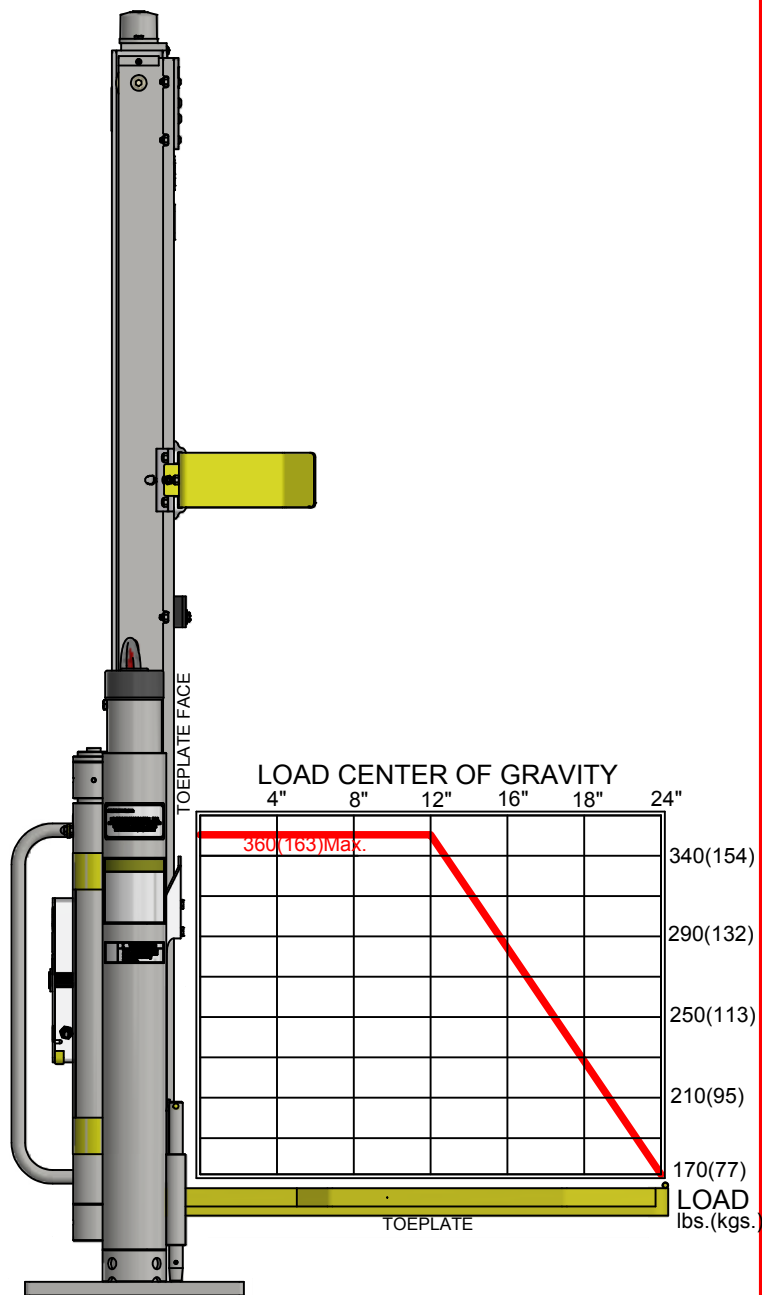

NOTE: This is a copy of the Load Chart on the Inner Frame of the Lift Gate Unit.

### INSTRUCTIONS:

The above Loading Chart indicates the maximum load that can be lifted by the LiftGate Unit at a specific center of gravity. The center of gravity is measured as the distance from face of the Toeplate to the balance point of the load. Estimate the weight of the load and the center of gravity distance out from the face of the Toeplate. Locate on the chart the Weight/Center of Gravity location for the load. The load must not exceed the weight limit for the given center of gravity distance.

## POWERMATE 360Lb. LIFTGATE LOAD CHART

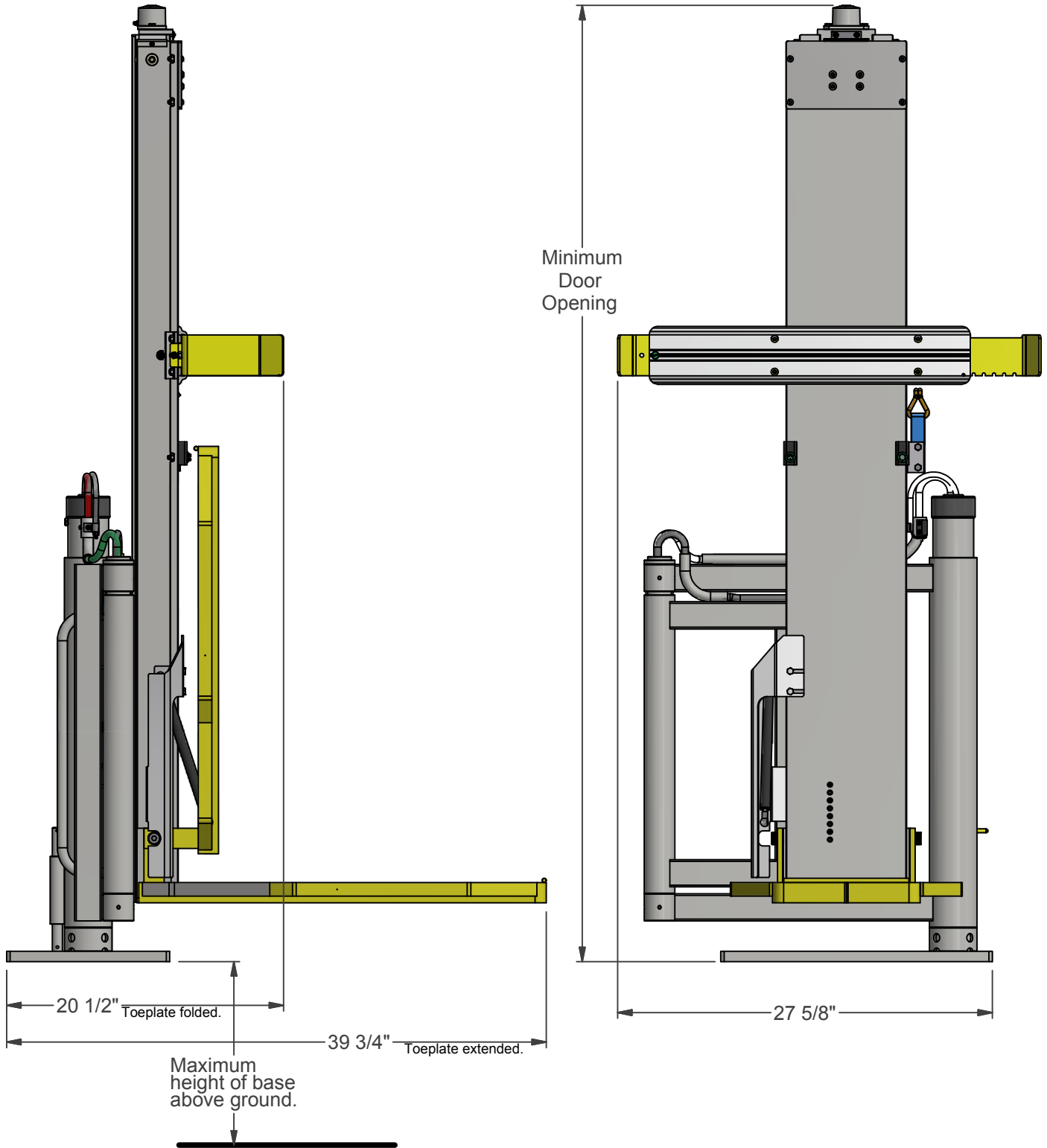

LiftGate Model No.	Minimum Door Opening	Maximum Height of Base above ground.
LV-7	71.50" (1816mm)	39" (990mm)

**INSTALLATION DIMENSIONAL REQUIREMENTS**

## INSTALLATION KIT

Your installation package should include the following:

1 **PowerMate® LiftGate™** Unit complete with pre-drilled Base

1 Wiring Kit which includes the following:

- 1 Bolt-Down Fuse Holder
- 1 125A
- 1 Fuse Holder Cover
- 1 Cable Splice 6Ga.
- 20 11" Cable Ties
- 1 Heat Shrink Tube 3/4" x 2"
- 1 Heat Shrink Tube 3/4" x 4"
- 4 Lock Pin Plug
- 1 5/16-18NC x 1/2" Bolt
- 1 5/16-18NC Jam Nut
- 1 5/16" Lock Washer
- 1 Fuse Block Wire Assembly
- 1 Hook-up Wire Assembly

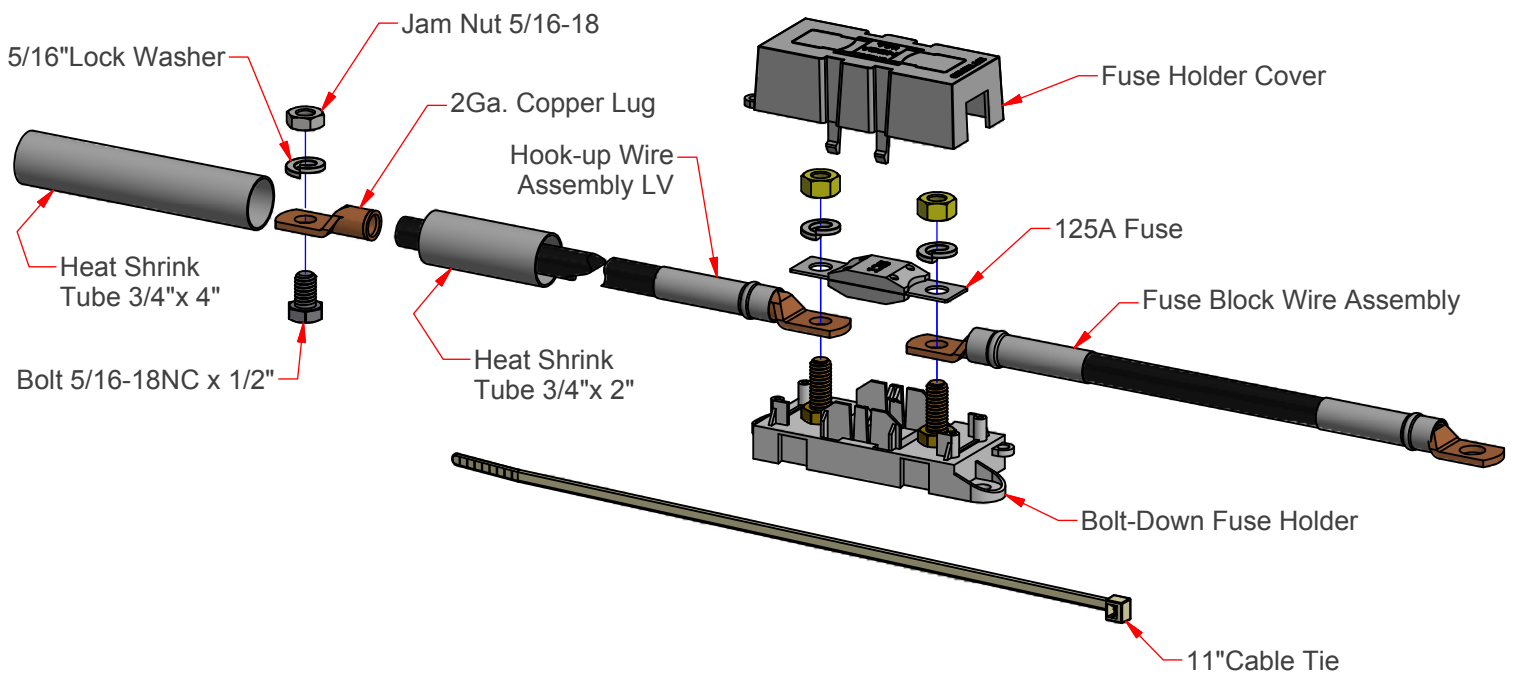

## **ADDITIONAL ITEMS & TOOLS**

The installer will need to provide following tools and materials to proceed with installation:

- Drill with 13/32" Metal Drill Bit.
- 1" to 2" Metal Hole Saw.
- Wire Cutter.
- Crimping Pliers.
- 9/16 Wrench.
- 9/16 Socket & Ratchet.
- 3/8"-16NC Bolts of suitable length\*.
- Wire Loom for wire protection.
- Steel Flat Bar, Angle, and/or C-Channel for vehicle floor reinforcement.
- Screw or Bolt/Nut combination to secure Ground Lug Terminal to vehicle frame.

### **NOTE:**

Some adjustments to the Unit's Base Plate may need to be made in order to fit the Unit around some areas of the vehicle (wheel wells, etc.) A cutting torch may be required to reshape the Unit's Base Plate.

\* The length of the Bolts are dependant on thickness of vehicle floor and vehicle floor reinforcement. Therefore, bolt length can only be determined at time of installment.

**INSTALLING YOUR PowerMate® LiftGate™**

**STEP 1: Determining the location of unit installation.**

- A. Although you will want the Unit placed close to the rear doors and side of the vehicle, you will need to ensure the proper allowances:
- I. Make sure there is enough room to close the rear doors.
  - II. The Base Pole must be far enough away from the vehicle wall to clear the doorway when swinging out, and allow you to easily access the Locking Pin.

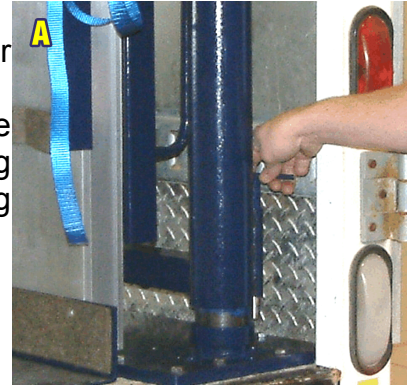

Below Example:  
LG-6 LiftGate™ placement in rear location of a truck box.

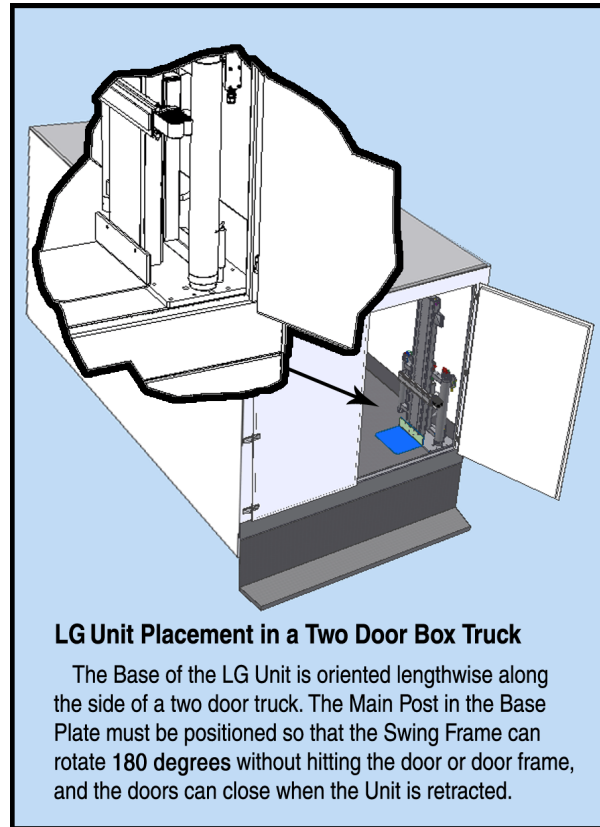
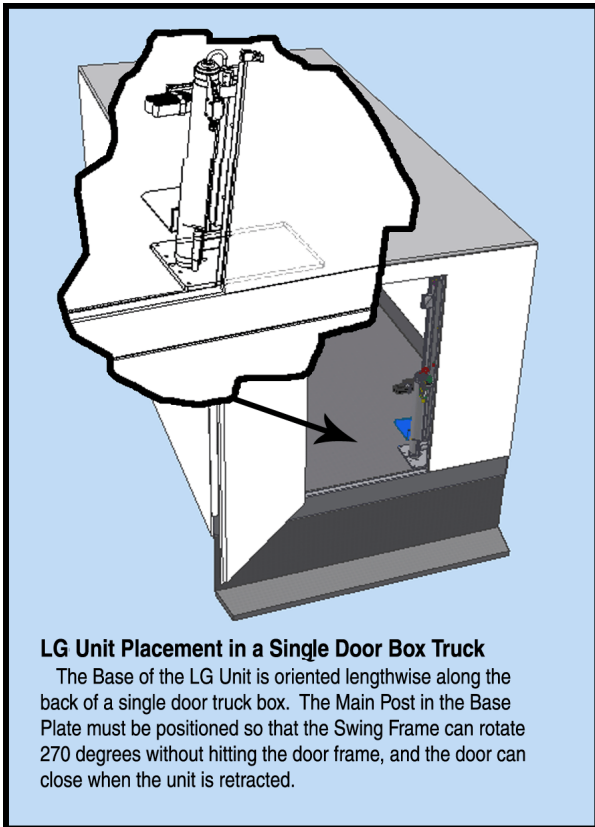



- B. Position the Unit in the vehicle and mark the outline of the Base Plate on the floor. Using a transfer punch and the Unit Base as a template, mark the bolt hole locations on the vehicle floor. Move the Unit out of the way. Using the dimensions provided in the sketch below, mark the center point of the large hole.

**CAUTION!!**

Before any holes are made in the vehicle floor, ensure the following: The large hole for the wiring must not damage the vehicle's supporting structure. Check the underbody of the vehicle to ensure the hole locations will not interfere with brake or fuel lines, fuel tank, wiring, or any other critical areas of the vehicle. If the area is not free of obstacles, re-position the Unit and repeat this step.

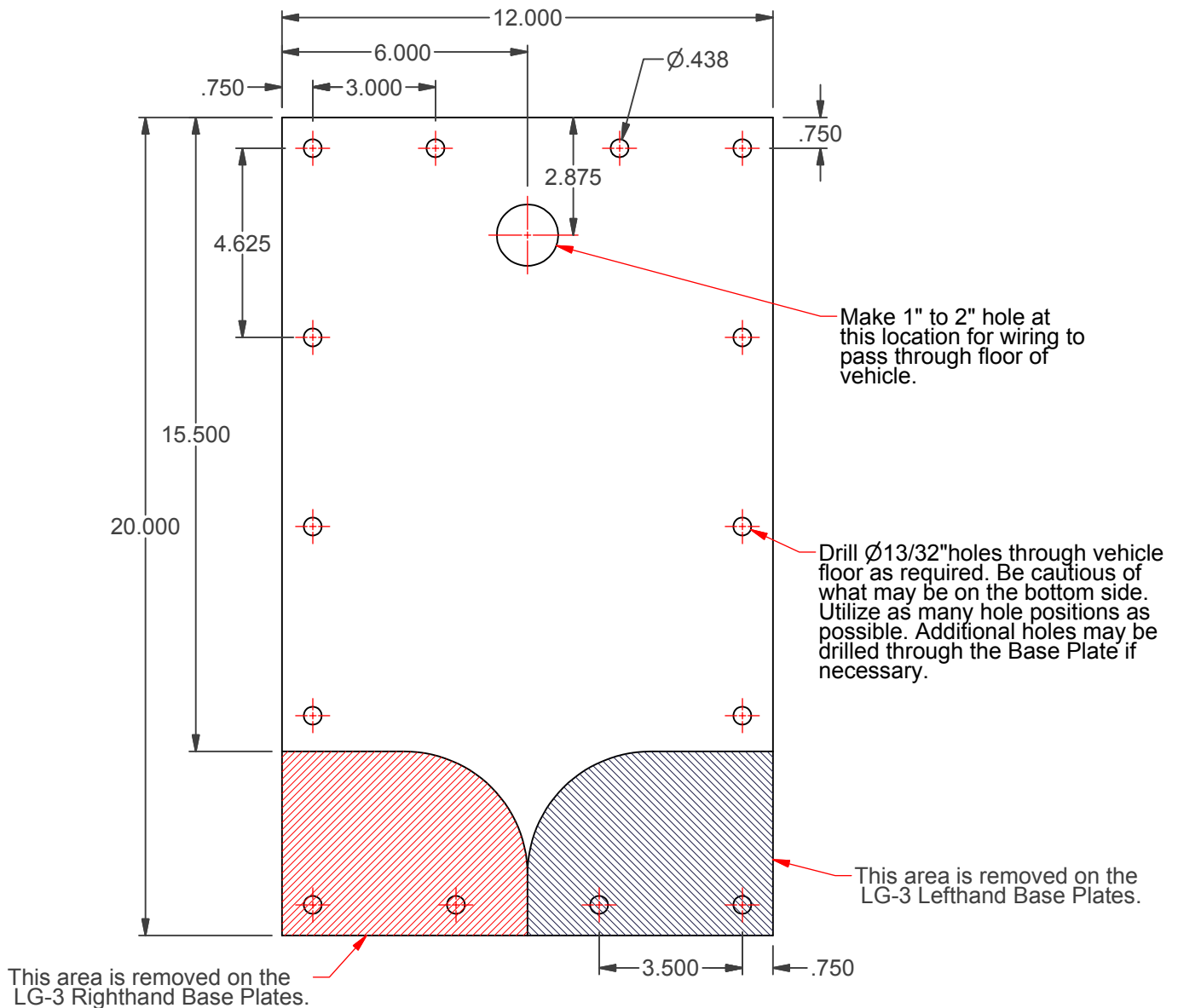

**POWERMATE LIFTGATE  
BASE HOLE LOCATIONS**

**INSTALLING YOUR PowerMate® LiftGate™**

**STEP 2: Installing the Unit**

- C. Proceed to drill the marked large hole and 13/32" holes into the floor of the vehicle. **Use as many bolt holes in the Base as possible.**

**NOTE:**

In some instances it may not be possible to utilize all the bolt holes due to the structuring underneath the vehicle floor. In these cases, additional holes can be added.

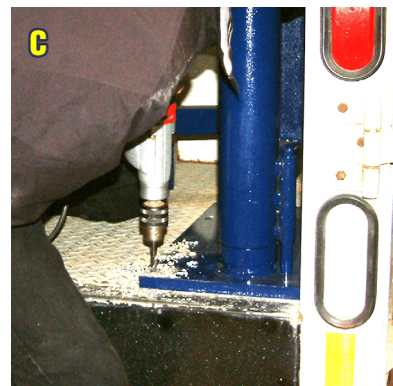

**CAUTION!!**

Be sure to not drill into anything vital under the floor.

- D. Reposition the **PowerMate® LiftGate™** Unit over the marked outline, lining up the large hole with the Main Post. Tip the Unit back to fish out the two wires hidden in the Main Post. Direct the wires through the large hole in the floor.

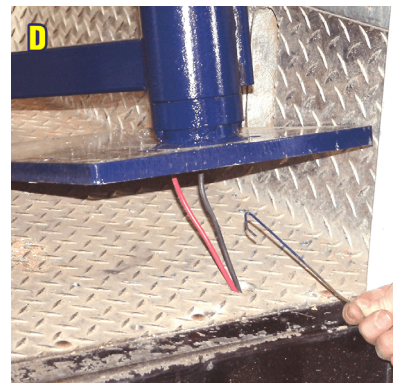

**CAUTION!!**

Care must be taken not to damage the wires.

- E. The installer is required to reinforce the Unit under the floor, below the Base Plate, with Steel Flatbar, Angle, and/or C-Channel.

**NOTE:**

Reinforcing steel will need to be measured, cut to size and drilled with 13/32" holes.



INSTALLING YOUR *PowerMate® LiftGate™*

- F. Secure the Base to the floor and the reinforcing steel with 3/8"-16NC Bolts, Washers and Lock Nuts.



STEP 3: Running the wires

**CAUTION!!**

The best and easiest way to route the wire from the Unit to the vehicle battery is to follow the path from the rear lights. If this is not feasible you must avoid the following:

- I. Any heat sources. EG. Exhaust system.
- II. Any pinch points. EG. Suspension system.
- III. Any areas that may cause chaffing to occur on the wiring.

- G. The **BLACK** wire that exits the Base Assembly and is fed through the floor must be fastened to a suitable Ground on the vehicle frame.
- H. Slip a piece of Heat Shrink Tube over the **RED** wire.
- I. Connect the **RED** wire to the 6Ga. wire using the 6Ga. Cable Splice and shrink the tubing over the connection.
- J. Provide a protective wire loom for the entire length of wire installation including up through the floor into the Base Assembly.

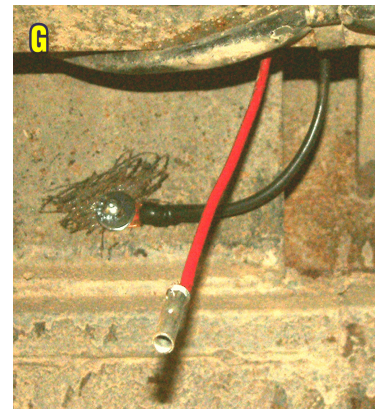

**INSTALLING YOUR PowerMate® LiftGate™**

K. Route the 6Ga. wire to the vehicle battery, securing wire to vehicle frame as required.

L. Slip a piece of Heat Shrink Tube over the 6Ga. wire. Join wire to Fuse Holder with 6Ga. Cable Splice and shrink tubing over the connection.

M. Attach Cable Lug to **POSITIVE** post of the battery.

N. Insert the 125A Fuse into the Fuse Holder and attach the Fuse Holder Cover.

O. Test the Unit.



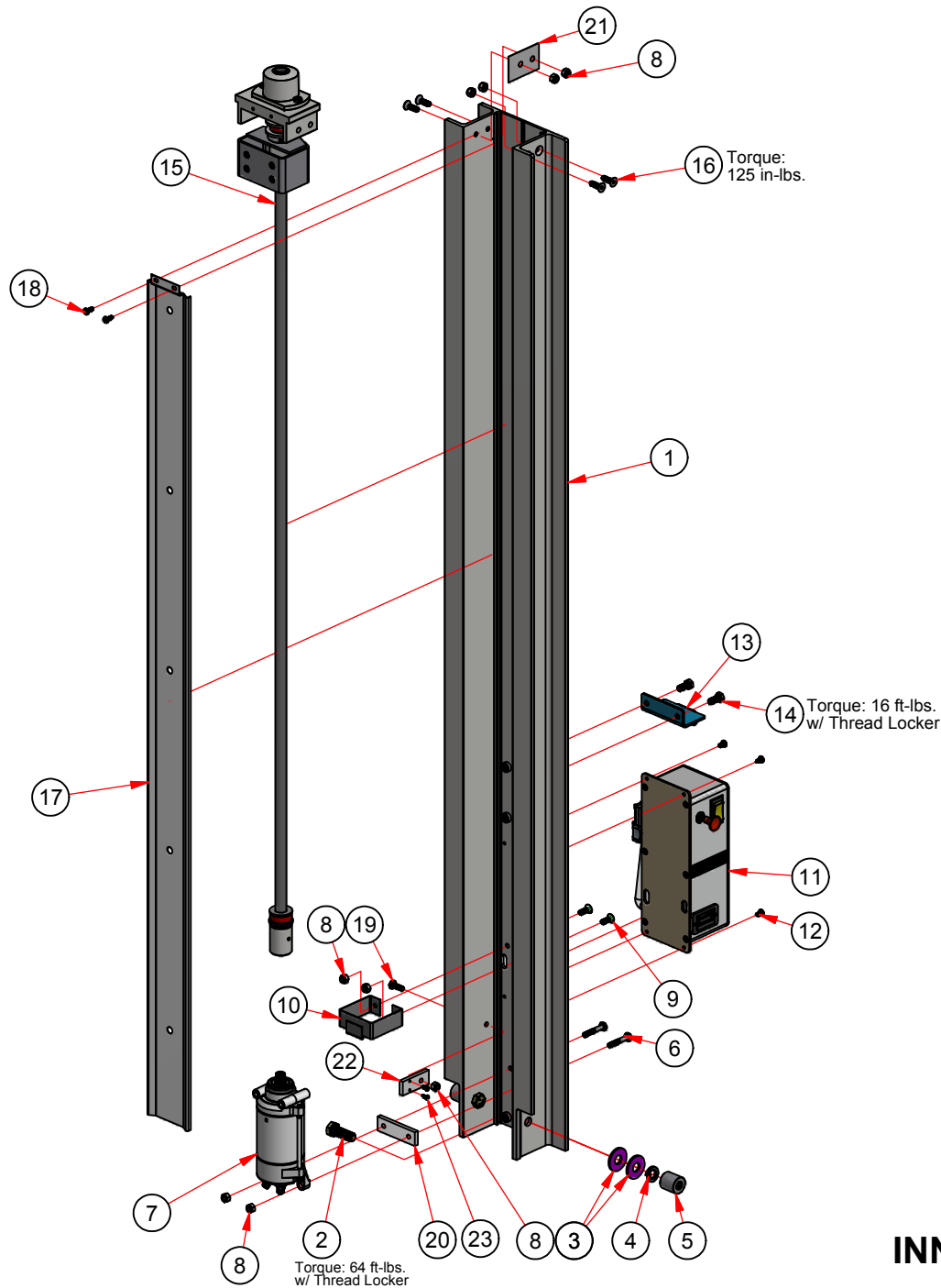

PARTS LIST			
ITEM	QTY	PART No.	DESCRIPTION
1	1	380037A	INNER FRAME SUB-ASSEMBLY LV-7
2	2	050720A	BOLT 1/2-13NC 1 1/2"HH GR5 ZINC
3	4	055640A	WASHER 1/2"PLATE 1 3/8"LS
4	2	050780A	WASHER 1/2"LOCK
5	2	055251A	ROLLER AXLE LS
6	2	050640A	BOLT 1/4-20NC x 1 1/2"HH GR5 ZINC
7	1	050860D	ELECTRIC MOTOR
8	9	050610A	NUT 1/4-20 RING LOCK ZINC
9	2	050560A	SCREW CS FLAT SLOT 1/4-20 x 3/4
10	1	310280A	SCREW GUARD BRACKET LS PF
11	1	387907D	CONTROL BOX ASSEMBLY LV-7
12	4	050575A	SCREW THRD CUT 10-32 x 3/8
13	1	385270A	INNER FRAME HANGER PF
14	2	050770A	BOLT 5/16-18 x 3/4"HH GR5 ZINC
15	1	388017E	SCREW ASSEMBLY LV-7
16	4	050645A	BOLT 1/4-20 x 7/8 CS HEX
17	1	350277B	LIFT CART SCREW GUARD LC-7 PF
18	2	050576A	SCREW THRD CUT 10-24 x 1/2
19	1	050750A	BOLT 1/4-20NC x 3/4"HEX. HD. ZINC
20	1	110119A	MOTOR WASHER BAR
21	1	385785A	SHIM PF
22	1	110118A	SENSOR SHIM
23	2	050594A1	SCREW No.6 x 3/8"

## INNER FRAME ASSEMBLY LV-7



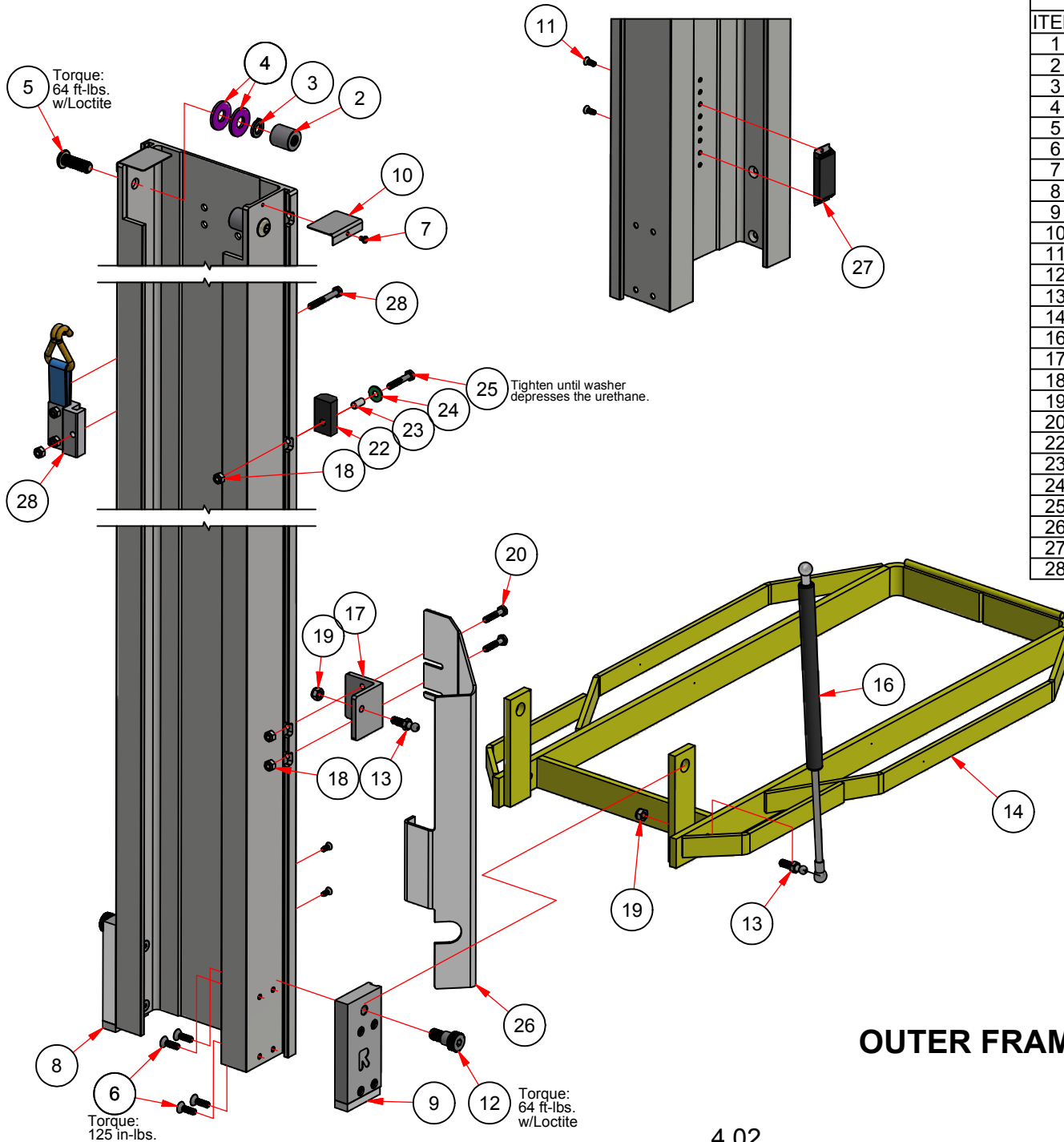

PARTS LIST			
ITEM	QTY	PART No.	DESCRIPTION
1	1	180027F	OUTER FRAME LV-7
2	2	055251A	ROLLER AXLE LS
3	2	050780A	WASHER 1/2"LOCK
4	4	055640A	WASHER 1/2"PLATE 1 3/8"LS
5	2	055300A	BOLT HXSOC BUTTON 1/2 x 1 1/2 LS
6	8	050645A	BOLT 1/4-20 x 7/8 CS HEX
7	2	050574A	SCREW THRD CUT 8-32 x 1/4
8	1	380180C	BACK BLOCK ASSEMBLY LH LV-7
9	1	380185C	BACK BLOCK ASSEMBLY RH LV-7
10	2	355286A	ROLLER GUARD TOP LC PF
11	2	050577A	SCREW THRD CUT 10-24x1/2"CS
12	2	050748A	BOLT 5/8 x 1/2"Lg. SHOULDER
13	2	080842A	GAS SPRING BALL STUD
14	1	385810C	TOEPLATE BAR LOOP PF LV-7
16	1	080840A	GAS RETRACTION SPRING
17	1	180175B	GAS SPRING BRACKET LV-7
18	3	050610A	NUT 1/4-20 RING LOCK ZINC
19	2	050620A	NUT 5/16-18NC NYLON LOCK ZINC
20	2	050530B	BOLT 1/4-20 x 1 1/4 HH ZINC
22	2	050101C	URETHANE LOCK
23	2	051260B	SPACER STEEL 5/16 x 5/8
24	2	050070A	WASHER PLATE 1/4 ZINC
25	1	050640A	BOLT 1/4-20NC x 1 1/2"HH GR5 ZINC
26	1	180412C	GAS CYLINDER GUARD LV-7
27	1	387827A	MAGNET - RECTANGULAR ASSY
28	1	389491A	HOOK STRAP ASSEMBLY LV-7

### OUTER FRAME ASSEMBLY LV-7



PARTS LIST			
ITEM	QTY	PART No.	DESCRIPTION
1	1		LV-7 INNER FRAME STAGE
2	1		LV-7 OUTER FRAME STAGE
3	4	055250A	ROLLER WHEEL L SERIES
4	4	050785A	BOLT 5/16-18 x 3/4" BUTTON HEAD CAP
5	1	180155A	DOUBLER - OUTER FRAME LV-7
6	4	050757A	BOLT 1/4-20 x 1" BUTTON HEAD CAP
7	4	050610A	NUT 1/4-20 RING LOCK ZINC
8	1	389336D	BACK BAR ASSEMBLY LV-7

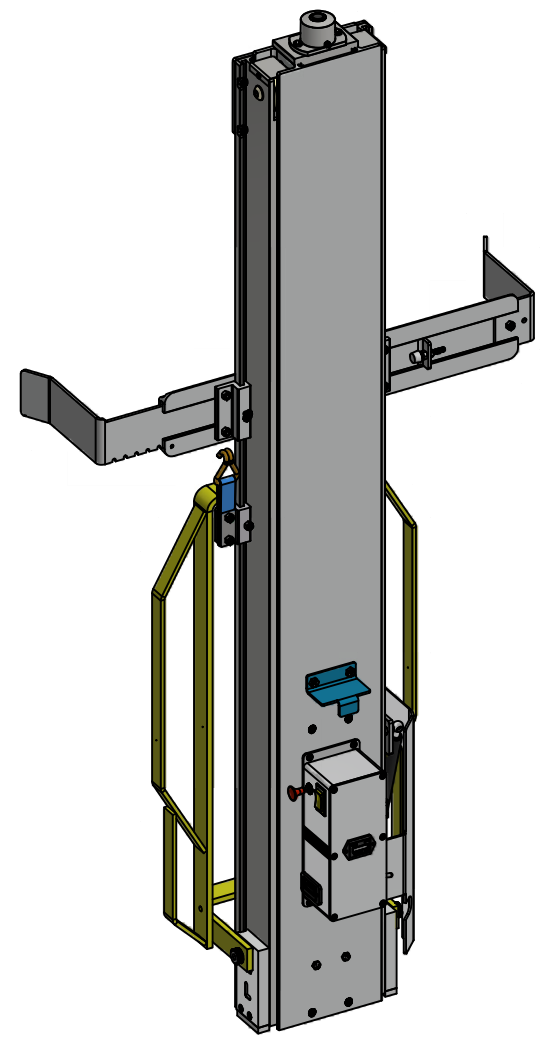
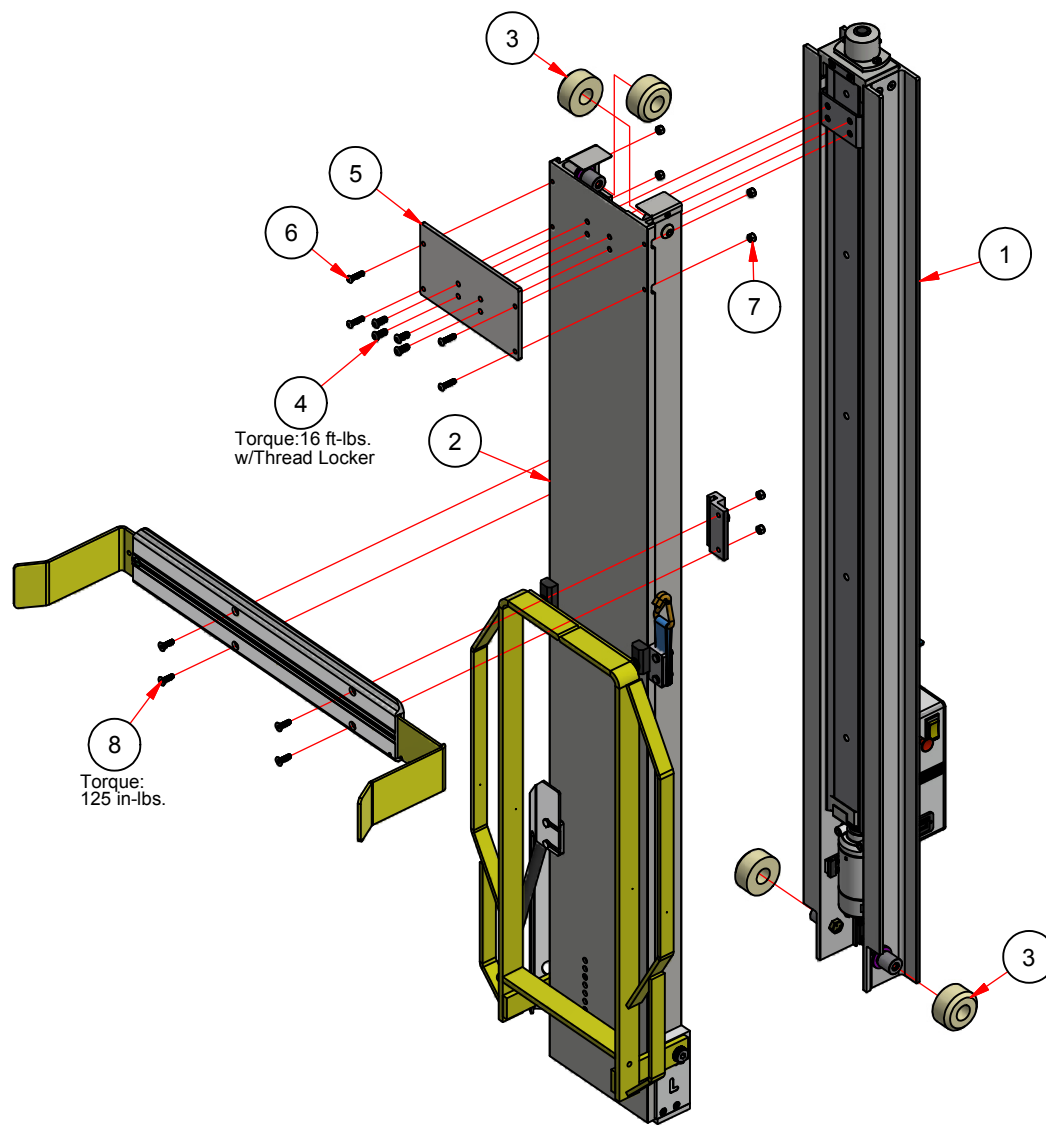

**INNER OUTER FRAME ASSEMBLY LV-7**

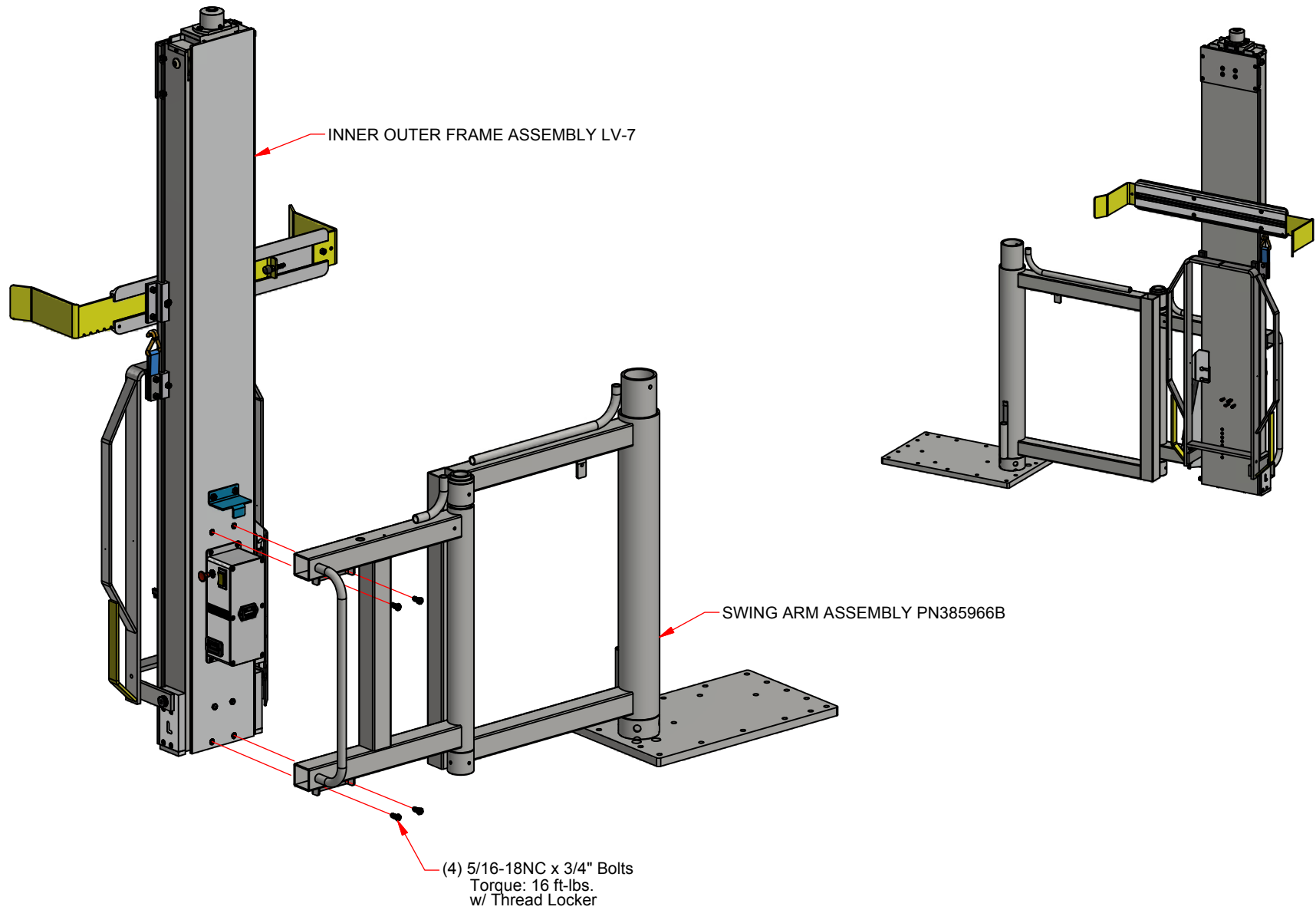

## INNER/OUTER FRAME - SWING ARM ASSEMBLY LV-7

4.04

PARTS LIST			
ITEM	QTY	PART No.	DESCRIPTION
1	1	180160B	CONTROL BOX REAR PLATE LV-7
2	1	051568A	TAPE HEAT TRANSFER 4.92"
3	1	052810A	SOLID STATE CONTROLLER
4	1	180150A	CONTROL BOX TOP HALF LV-7
5	1	060220A	SWITCH ROCKER DPDT 6 TERMINAL
6	1	080790A	SWITCH EXTRA HEAVY DUTY
7	1	180140D	CONTROL BOX BOTTOM LV-7
8	1	051366A	CIRCUIT BREAKER TOGGLE
9	1	387500C	CONTROL BOX IN CONNECTION LV-7
10	1	301522A	BUZZER
11	1	180170B	CONTROL BOX FRONT COVER LV-7
12	12	050578A	SCREW THRD CUT 10-24x5/8"CS TYPE F
13	1	090767B	CONTROL WIRE LV-7
14	1	387235A	WIRE CONTROLLER-SWITCH LV-7
15	1	387240A	WIRE CIRCUIT BREAKER-SWITCH
16	1	387290B	WIRE ASSEMBLY MOTOR BLACK LV-7
17	1	387295B	WIRE ASSEMBLY MOTOR RED LV-7
18	1	051305A	BATTERY METER
19	1	387306A	WIRE ASSEMBLY BATTERY METER
20	1	387305A	WIRE 18Ga. 5 DC-DC
21	1	387425B	LOWER REED SWITCH WIRE ASSY
22	1	051307A	LED STRIP
23	1	051306A	HOUR METER LV-7
24	1	387206A	WIRE 26Ga. DC-DC 6"
25	2	387207A	WIRE 26Ga. DC-DC-DC 6" V

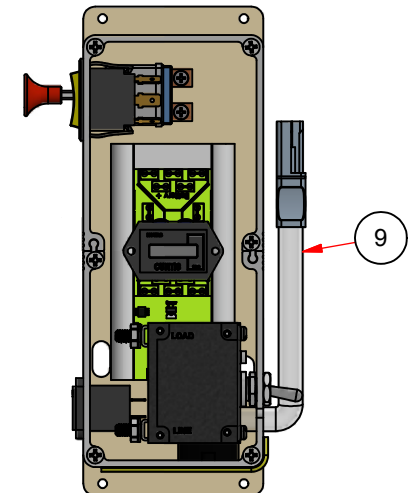
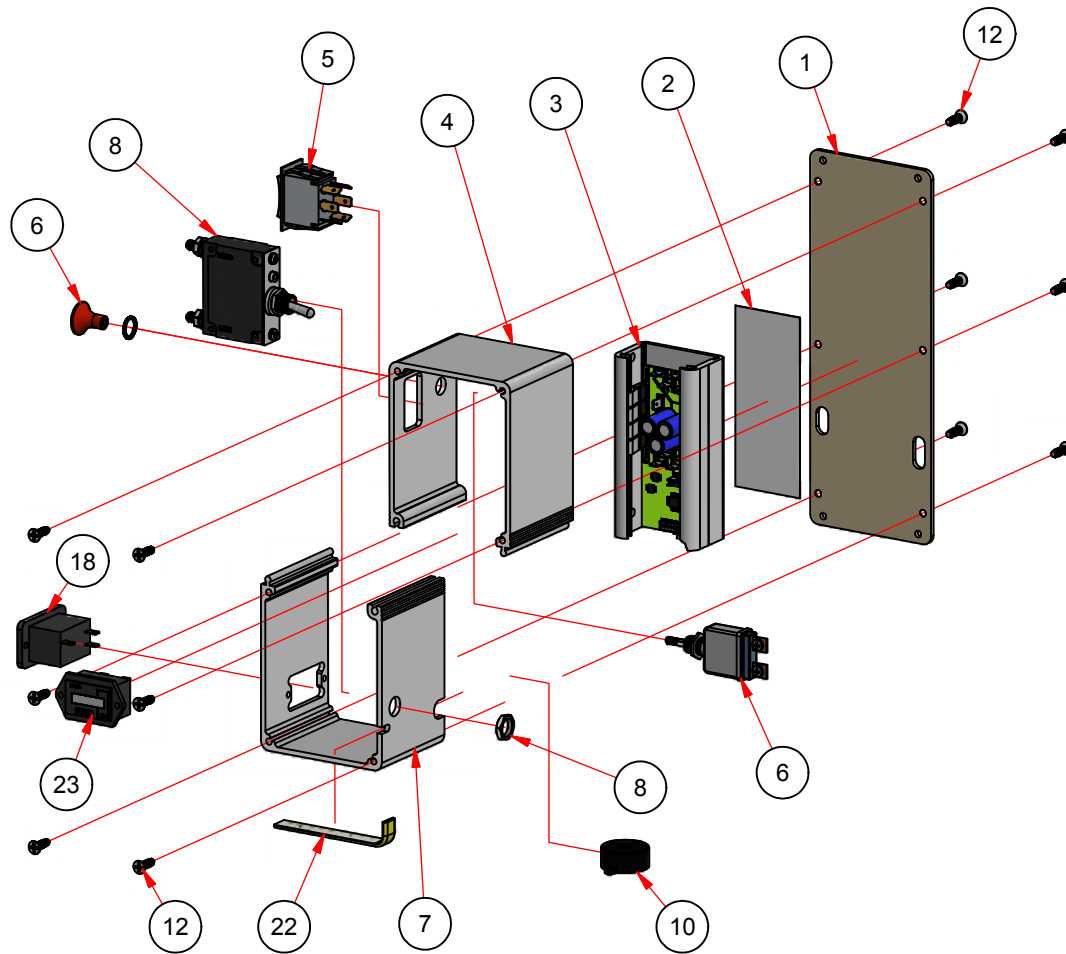

NOTE: Front Cover PN180170B not shown for clarity.  
 Item 23 Hour Meter comes with its own screws and nuts.  
 Wires not shown. Refer to wiring drawing for connection details.

## CONTROL BOX ASSEMBLY LV-7

4.06

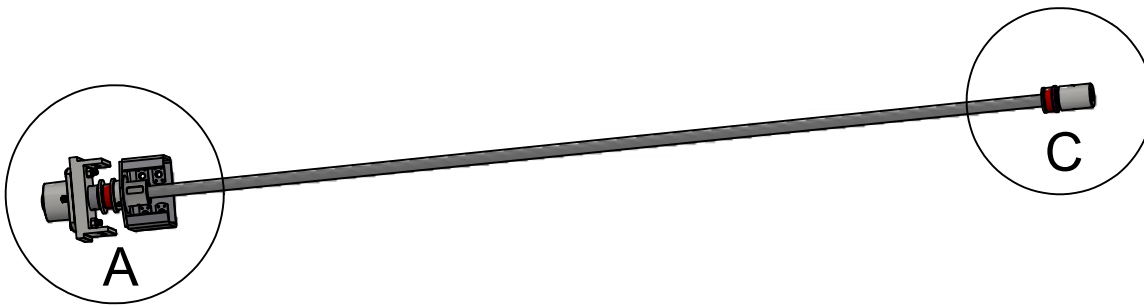
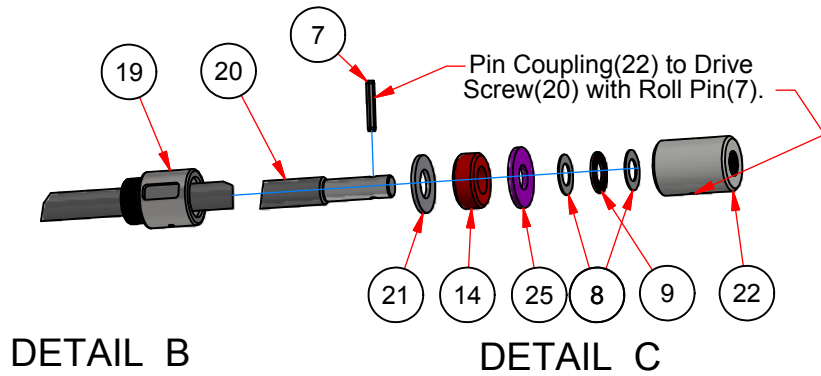
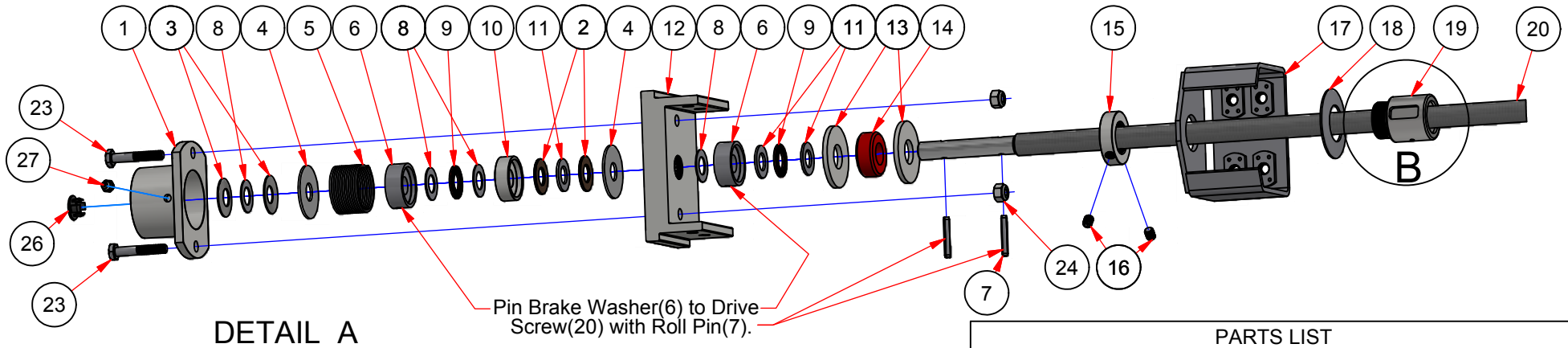

**SCREW ASSEMBLY LV-7**

4.07

PARTS LIST			
ITEM	QTY	PART No.	DESCRIPTION
1	1	181450B	BRAKE CAP LV-7
2	2	050840A	WASHER THRUST BRONZE .060
3	2	050052A	WASHER DISC SPRING .500"x 1.100"
4	2	050940B	WASHER BRAKE TOP
5	1	050800C	BRAKE SPRING
6	2	050820F	WASHER TOP BRAKE DRIVE
7	3	051680A	ROLL PIN SPIROL 3/16"x 1 1/8"
8	6	050810A	WASHER THRUST STEEL 1/2"x .030
9	3	050120A	BEARING THRUST STEEL
10	1	050850B	WASHER BOTTOM BRAKE DRIVE
11	3	050920A	WASHER THRUST STEEL 1/2"x .060
12	1	310070D	BEARING RETAINER ASSEMBLY LS
13	2	050040A	WASHER 5/8"PLATE ZINC
14	2	100700A	URETHANE BUMPER 1/2"L x 5/8"ID
15	1	082090A	BALLNUT LOCKNUT M26 x 1.5P
16	2	050550B	SET SCREW 1/4-20NC x 5/16
17	1	380250B	BALLNUT BRACKET LIFTGATE PF
18	1	080830A	WASHER DISC SPRING M26
19	1	080170A	BALLNUT METRIC (5/8"Version)
20	1	080157C	DRIVE SCREW 15.875mm x 1395mm
21	1	051850B	WASHER 5/8 SAE ZINC
22	1	300840A	COUPLING PAINT FINAL
23	2	050640A	BOLT 1/4-20NC x 1 1/2"HH GR5 ZINC
24	2	050610A	NUT 1/4-20 RING LOCK ZINC
25	1	055640A	WASHER 1/2"PLATE 1 3/8"LS
26	1	052200A	PLUG NYLON BLACK 1/2"HOLE
27	1	053095B	GREASE FITTING - THREADED
28	1	053103A	OIL LUBRICATING GREASE

PARTS LIST			
ITEM	QTY	PART No.	DESCRIPTION
1	1	050120A	BEARING THRUST STEEL
2	1	050800C	BRAKE SPRING
3	3	050810A	WASHER THRUST STEEL 1/2"x .030
4	1	050820F	WASHER TOP BRAKE DRIVE
5	2	050840A	WASHER THRUST BRONZE .060
6	1	050850B	WASHER BOTTOM BRAKE DRIVE
7	1	050920A	WASHER THRUST STEEL 1/2"x .060
8	1	051680A	ROLL PIN SPIROL 3/16"x 1 1/8"
9	2	050940B	WASHER BRAKE TOP
10	2	050052A	WASHER DISC SPRING .500"x 1.100"Dia.

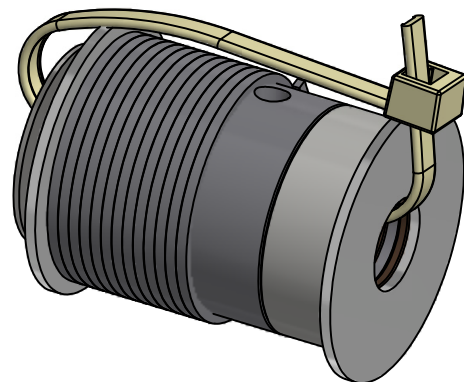
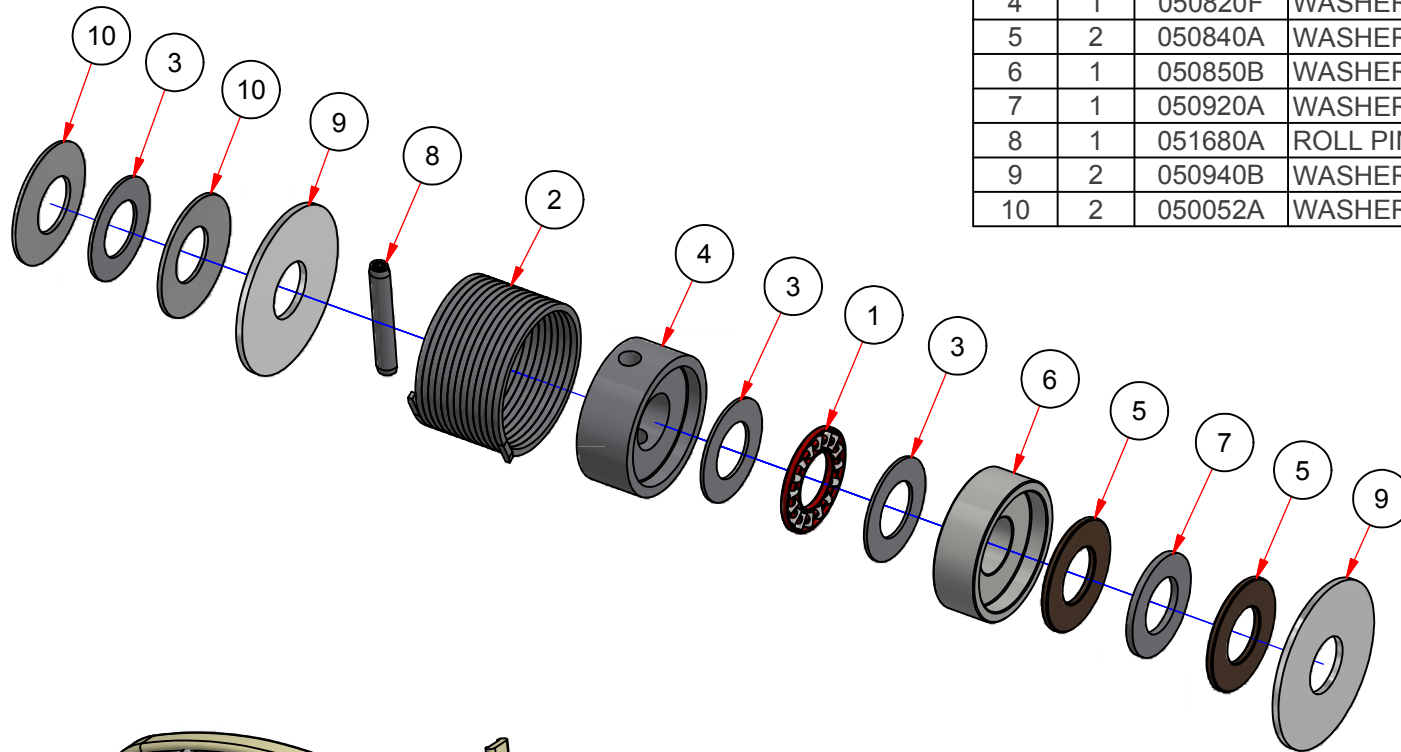

**BRAKE ASSEMBLY KIT**  
(as it is packaged)

**BRAKE ASSEMBLY KIT**  
**PN 400151**  
4.08

PARTS LIST			
ITEM	QTY	PART No.	DESCRIPTION
1	2	050040A	WASHER 5/8"PLATE ZINC
2	1	050120A	BEARING THRUST STEEL
3	1	080830A	WASHER DISC SPRING M26
4	2	050920A	WASHER THRUST STEEL 1/2"x .060
5	1	100700A	URETHANE BUMPER 1/2"L x 5/8"ID

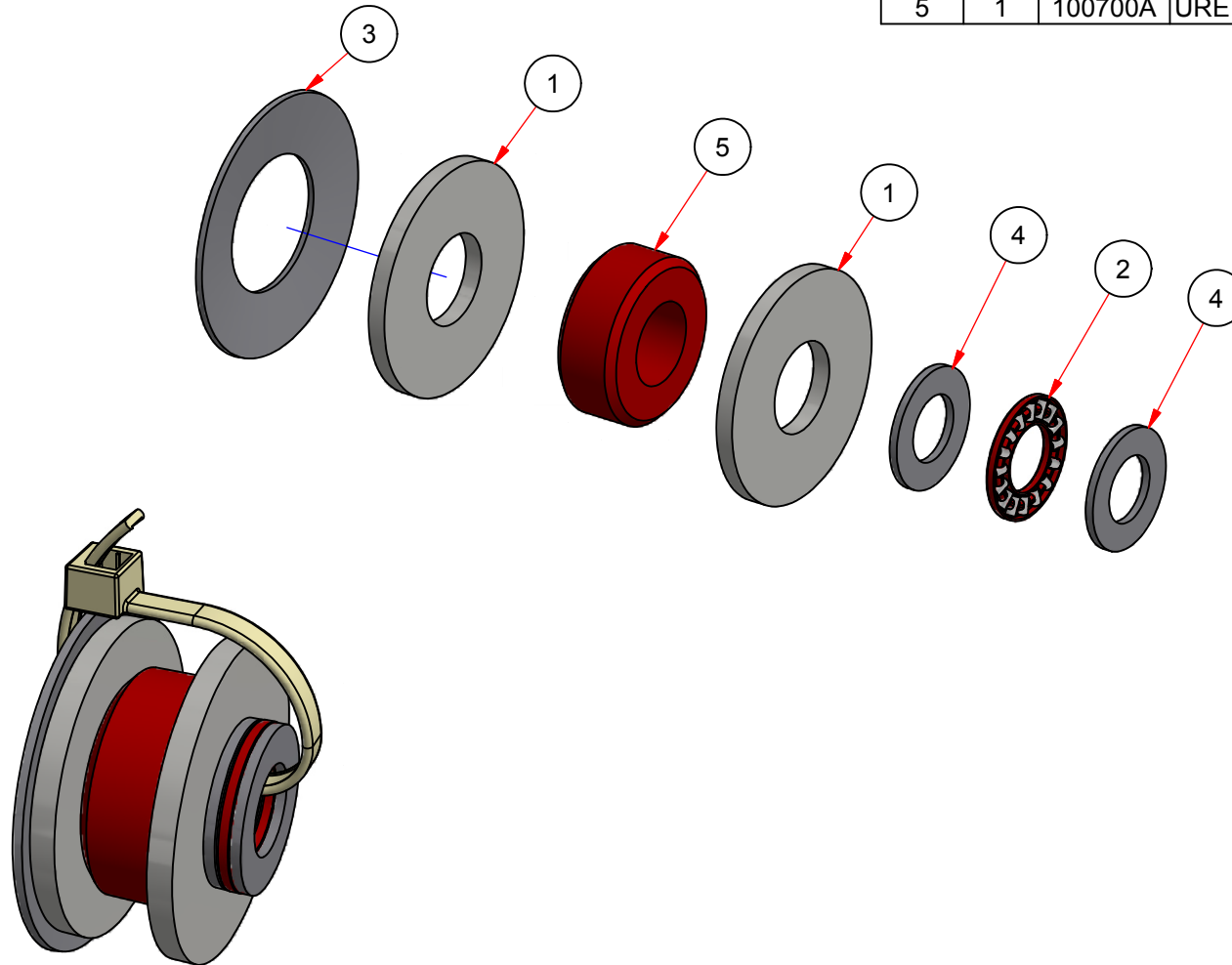

**BEARING OVERRIDE KIT**  
(as it is packaged)

**BEARING OVERRIDE KIT (Metric)**  
**PN 400161**  
4.09



## **MAINTAINING YOUR PowerMate® LiftGate™**

A properly maintained machine ensures trouble free and risk free operation. Regular maintenance of your **PowerMate LiftGate** will ensure that it is always capable of performing at peak efficiency resulting in less downtime caused by preventable repairs.

After every twenty-five hours of operation, ensure the following:

1. The Base Plate is securely anchored. Tighten Bolts if necessary.
2. Wire Looms at hinge points are not twisted or encumbered during swing out movement.
3. Apply non-flammable lubricant to hinge points. Wipe off excess lubricant.
4. Check up/down operation of Unit. The drive mechanism should stop when unit reaches the retracted position. Drive motor should stop during extension operation when the Toeplate makes contact with any surface.
5. Look for excessive movement between Inner and Outer Aluminum Frames.
6. Apply lubricant (EG. Oil) to Top Rollers. Wipe off excess oil.
7. Check that Toe Plate is secure and not bent.
8. Check to see if Back Bar mounting hardware is secure.
9. Ensure Drive Screw Guard and Roller Guards are in place and secure.
10. Ensure Mandatory Decals are in place.

After every twelve months, ensure the following:

1. Inspect complete assembly for wear and stress. Repair as required.
2. Inspect Drive Screw Assembly Mounts and Bearings for wear and stress. Replace where necessary.
3. Check wiring integrity including Motor brushes. Replace where necessary.
4. Replace Mounting hardware as required.

## Procedure for Repairing the LV-TL Series Drive Screw Assembly

*NOTE: Read all instructions carefully before attempting to make repairs to any part of the drive screw assembly. Refer to the Screw Assembly Drawing. For this procedure, it will be necessary to remove any accessories like screw guard, back bars, etc.*

### SCREW ASSEMBLY REMOVAL

There are two methods to gain access to and remove the Screw Assembly from the LiftGate LV-7. They are as follows:

Method 1. Swing the LiftGate unit out of the vehicle and engage the Base Main Arm Lock Pin.

Extend the unit until the Toeplate is just touching the ground. The intent is not to have any load on the Screw Assembly to facilitate the removal of the Outer Frame Assembly.

Move the Circuit Breaker Switch to the OFF position.

Remove the Fuse at the Battery source.

Remove the four Button Head Cap Screws (3/16" Allen Key) retaining the Outer Frame to the Screw Assembly Ballnut Bracket.

Raise the Outer Frame Assembly vertically until completely dis-engaged from the LiftGate Unit. This step will require a ladder or elevated surface. Two people recommended.

Remove the Roller Wheels from the Inner and Outer Frame assemblies.

Remove the two 10-24NC Screws (Phillips Screw Driver) at the top of the Screw Guard.

Pull the top of the Screw Guard out 1/2" from the Inner Frame, then vertically out of the Ballnut Bracket.

Remove the four top 1/4" Countersunk Screws retaining the Bearing Retainer (7/16" Wrench and 5/32" Allen Key).

Grip the Screw Assembly and remove up and out, disengaging the spline of the Motor.

Method 2. Swing the LiftGate unit out of the vehicle and engage the Base Main Arm Lock Pin.

Move the Circuit Breaker Switch to the OFF position.

Remove the Fuse at the Battery source.

Disengage the Power Connectors on the side of the Control Box.

Remove the four 5/16" Bolts that fasten the aluminum Inner Frame to the Outer Arm Frame (9/16" Socket, Extension, and Ratchet Wrench). With help, lift the aluminum Inner/Outer Frame Assembly approximately 1" to disengage the Outer Arm Frame.

Lay the Inner/Outer frame assembly on a bench resting on the Control Box. Care must be taken not to damage the Hour Meter. The top of the assembly can be propped up to level the assembly.

Remove the four Button Head Cap Screws (3/16" Allen Key) retaining the Outer Frame to the Screw Assembly Ballnut Bracket.

Slide the Outer Frame assembly in the direction of the top Brake Cap, disengaging the Inner Frame assembly. Remove the Roller Wheels from the Inner and Outer Frame assemblies.

Remove the Plastic Plug from the Brake Cap at the top of the Screw Assembly.

Insert a 1/4-20NC Socket Head Cap Screw into the Brake Cap, engaging the top end of the Drive Screw. The Cap Screw should be tightened enough that when reversing the rotation it will cause the Drive Screw to move the Ballnut Bracket along the Inner Frame assembly. Move the Ballnut Bracket approximately halfway down the assembly.

Remove the two 10-24NC Screws (Phillips Screw Driver) at the top of the Screw Guard.

Pull the top of the Screw Guard out 1/2" from the Inner Frame, then horizontally out of the Ballnut Bracket.

Remove the four top 1/4" Countersunk Screws retaining the Bearing Retainer (7/16" Wrench and 5/32" Allen Key).

Grip the Screw Assembly and slide horizontally to disengage the spline of the Motor.

## Procedure for Repairing the LV-TL Series Drive Screw Assembly

*NOTE: Read all instructions carefully before attempting to make repairs to any part of the drive screw assembly. Refer to the Screw Assembly Drawing. For this procedure, it will be necessary to remove any accessories like screw guard, back bars, etc.*

### BRAKE ASSEMBLY REPLACEMENT

1. With reference to the Screw Assembly drawing for the particular model, remove the two 1/4"bolts(23) and nuts(24). Proceed to remove the brake cap(1), two disc spring washers(3), steel thrustwasher(2), washer retainer(4) and brake spring(5).
2. Drive out the 3/16" roll pin(7) taking care not to bend the screw shaft. Place a suitable support underneath the brake drive top washer(6) for this operation.
3. Remove the brake drive top washer(6), two steel thrust washers(8), thrust washer(9), brake drive bottom washer(10), two bronze thrust washers(2), the steel thrust washers(11), and the large steel washer(4).

**NOTE:** At this point, if it is intended to replace the Bearing Override, complete that procedure first before continuing with the brake re-assembly.

4. As per the screw assembly drawing, replace the brake assembly components (Brake Assembly Kit P/N 400151A ) in reverse order as follows: Items: 4-2-11-2-10-8-9-8-6-7-5-4-3-8-3. Note: The Disc Spring washers (3) are concave side away from each other. During assembly, place a few drops of light machine oil on the thrust bearing(9) only. Remember to support the brake drive top washer(6) when installing the 3/16" roll pin(7).
5. Install brake cap(1) and insert the 1/4"bolts(23) and fasten with the nuts(24). Go to procedure for re-assembly of machine.

### OVERRIDE BEARING ASSEMBLY

1. Remove the brake assembly as outlined in the Brake Assembly procedure.
2. Continue the disassembly by removing the Bearing Retainer Assembly(12),thrust washer (8), roll pin(7), brake washer(6) two steel thrust washers(11), steel thrust bearing(9), two plate washers(13), and the urethane bumper(14).

**NOTE:** At this point, if it is intended to replace the Ballnut or removing the Drive Screw for service/replacement, complete those procedures first before continuing with the override bearing replacement.

3. As per the screw assembly drawing, replace the override bearing components (Bearing Override Kit P/N 400161) in reverse order as follows: Items: 13-14-13-11-9-11-6-7-8-12. Apply a few drops of light machine oil to thrust bearing(9) and the roller bearing in the bearing retainer(12).
4. Replace the brake assembly components as per the Brake Assembly instruction step 4.

### DRIVE SCREW REMOVAL & INSTALLATION

1. Remove the brake assembly as outlined in the Brake Assembly procedure.
2. Remove the override bearing assembly as outlined in the Override Bearing Assembly procedure.
3. Apply a band of tape around the drive screw(20) at each end of the ballnut(19). This will prevent the ballnut from disengaging the drive screw until the appropriate time. The set screws(16) in the ballnut locknut(15) may be loosened and the locknut removed. Remove the drive screw(20) through the ballnut bracket(17) and remove the spring disc washer(18) from the drive screw.

**NOTE:** At this point, if it is intended to remove the ballnut (19) for replacement, complete the Ballnut Replacement procedure first, before re-installing the drive screw.

## Procedure for Repairing the LV-TL Series Drive Screw Assembly

*NOTE: Read all instructions carefully before attempting to make repairs to any part of the drive screw assembly. Refer to the Screw Assembly Drawing. For this procedure, it will be necessary to remove any accessories like screw guard, back bars, etc.*

4. To re-install the Drive Screw (20), place the Spring Disc Washer( 18) over the Ballnut thread, insuring the concave side of the Washer is oriented away from the round body of the Ballnut. Insert the Drive Screw (20) through the Ballnut Bracket (17) as per the assembly drawing. Thread the Ballnut Locknut (15) onto the Ballnut (19) and firmly hand tighten. Secure with the Set Screws. Remove the tape from the Drive Screw, if applied.
5. Continue the re-assembly process by returning to step 3 of the Override Bearing Procedure.

### SCREW ASSEMBLY INSTALLATION

1. Position the Ballnut Bracket approximately halfway along the Drive Screw. Engage the Coupling with the Motor spline while inserting the Top Bearing Retainer into the top of the Inner Frame. Ensure the four hole face of the Ballnut Bracket is facing outwards while doing this. Insert the four top Countersunk Screws and 1/4"Nuts (5/32"Allen Key and 7/16"Wrench) to secure the Top Bearing Retainer.
2. Pass the Screw Guard down through the Ballnut Bracket and engage the Screw Guard Bracket at the bottom above the Motor. Fasten the top of the Screw Guard to the Top Bearing Retainer with two 10-24NC Screws (Phillips Screw Driver).
3. Remove any nicks or burrs on the Roller Axles. Apply a light machine lubricant to the four Roller Axles and re-install the Roller Wheels. Wipe off excess lubricant.
4. IF Method #1 was used to disassemble the unit: Lower the Outer Frame Assembly onto the Inner Frame Assembly engaging all four Rollers. Lower the Outer Frame until the four face holes on the Outer Frame line up with the Ballnut Bracket holes. Apply thread locking Loctite to the four Button Head Cap Screws and re-fasten the Outer Frame to the Ballnut Bracket.
5. IF Method #2 was used to disassemble the unit: Slide/roll the Outer Frame assembly onto the Inner Frame assembly, starting from the Brake Cap end. Align the four face holes on the Outer Frame with holes in the Ballnut Bracket. Apply thread locking Loctite to the four Button Head Cap Screws and re-fasten the Outer Frame to the Ballnut Bracket. With help, hang the Inner/Outer Frame assembly on the Outer Arm Frame. Shift side to side to align the mounting holes. Fasten the assembly with the four 5/16-18NC Bolts (9/16"Socket, Extension, and Ratchet Wrench). Re-engage the two Power Connectors.
6. Install the Fuse at the battery source, move the Circuit Breaker Toggle Switch to on and test.

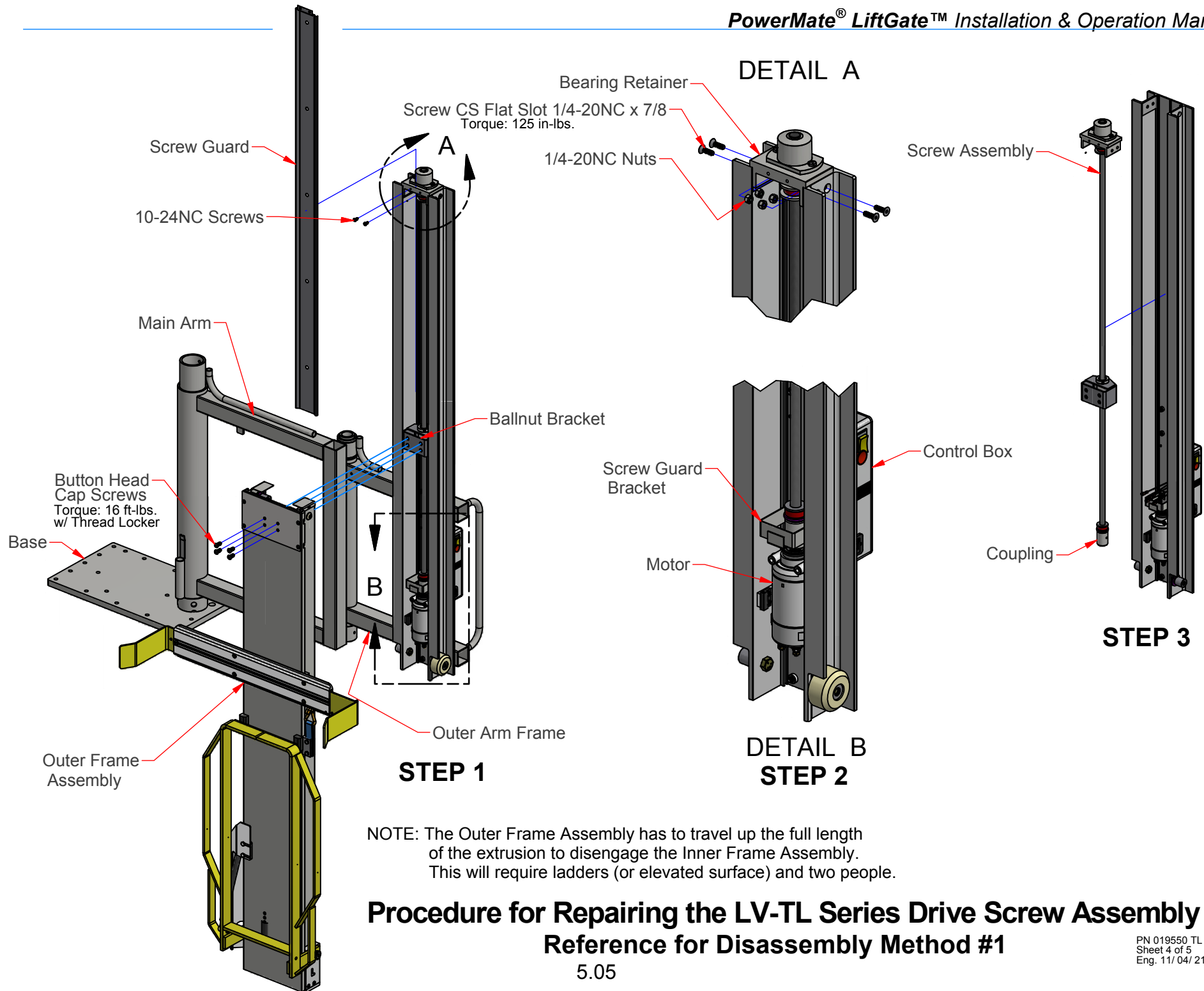

NOTE: The Outer Frame Assembly has to travel up the full length of the extrusion to disengage the Inner Frame Assembly. This will require ladders (or elevated surface) and two people.

**Procedure for Repairing the LV-TL Series Drive Screw Assembly**  
**Reference for Disassembly Method #1**

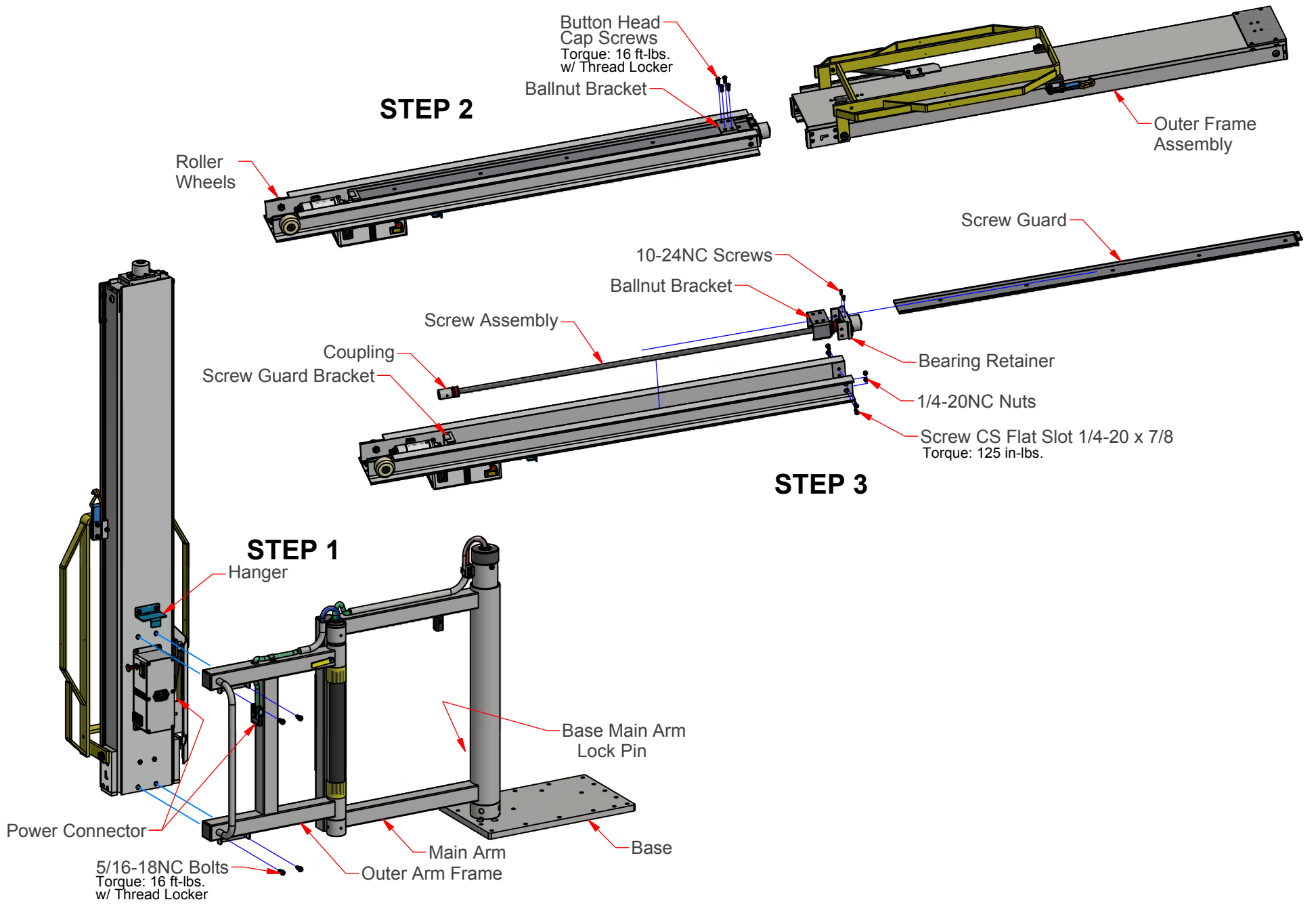

**Procedure for Repairing the LV-TL Series Drive Screw Assembly  
Reference for Disassembly Method #2**



**MOTOR REMOVAL**

Step 1. Remove the Outer Frame Assembly by following the Screw Assembly Removal instruction found in the "Procedure for Repairing the LV-Series Drive Screw Assembly". For this task the Screw Assembly may remain in place.

Step 2. Disconnect the Motor electrical wires by removing the two 10mm Nuts and Lock Washers.

Step 3. Remove the two 1/4-20NC Bolts and Nuts.

Step 4. Remove the Motor Spacer supporting the Motor bottom.

Step 5. Dis-engage the Motor spline from the Screw Assembly Coupling and remove.

NOTE: The Motor Wires are not shown for clarity.

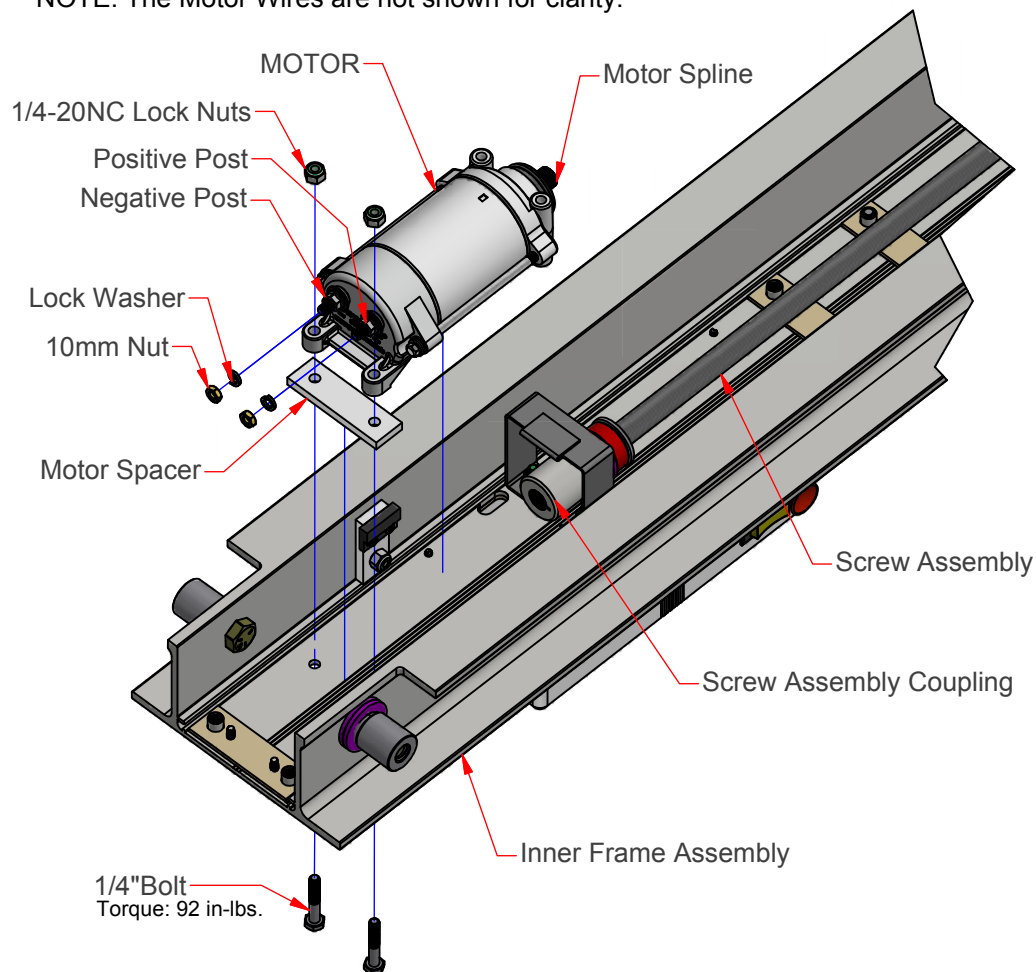
**MOTOR INSTALLATION**

Step 1. Engage the Motor Spline with the Screw Assembly Coupling with the Motor mounting lugs facing the inside of the Inner Frame extrusion.

Step 2. Insert the two 1/4" Bolts through the Inner Frame and install the Motor Spacer. Align the Motor Lugs with the 1/4" Bolts and slip the Bolts up into place. Insure the Motor is parallel and vertical against the Inner Frame. Secure the assembly with the 1/4" Lock Nuts.

Step 3. Re-attach the Motor wires. The red wire to the positive post and the black wire to the negative post. Install the Lock Washers and secure with the 10mm Nuts.

Step 4. Re-install the Outer Frame Assembly by following the Screw Assembly Installation instruction found in the "Procedure for Repairing the LV-Series Drive Screw Assembly". For this task the Screw Assembly has remained in place.

**MOTOR REMOVAL / INSTALLATION INSTRUCTION**



## BALLNUT REMOVAL AND REPLACEMENT

### PROCEDURE:

1. To begin, the screw assembly must be removed from the unit.  
Follow the procedure for Drive Screw removal and replacement.
2. Remove the tape from the drive screw that is keeping the ballnut in position, if installed.
3. Remove the coupling and adjacent components by removing the roll pin using a 1/8" punch and hammer. Support the screw assembly horizontally and the coupling on a solid surface, taking care not to bend the drive screw end.
4. Thread the old ballnut along the screw towards the short turned end until it is completely disengaged from the thread. Slide the old ballnut off the end of the short shaft. Note: All the balls in the old ballnut will fall out. Placing a catch bowl underneath the end will help containment.
5. Stand the drive screw vertically with the short turned end up.
6. To install the new ballnut remove the tie-wrap from the plastic arbor with a side cutter. Be sure the arbor does not disengage from the ballnut or all the balls in the ballnut will fall out.
7. Note the direction the ballnut must assemble to the drive screw. Slide the arbor over the drive screw short turned end until it stops at the start of the drive screw thread. Slide the ballnut off the arbor onto the screw and engage the drive screw thread. Allow the ballnut to spin down the screw to approximately halfway along its length. Band tape around the screw at both ends of the ballnut to keep the ballnut in position.
8. Remove the plastic arbor from the short end.
9. Re-assemble the coupling and adjacent components onto the drive screw short end in the order shown. Place the coupling horizontally on a solid surface. Align the cross holes in the coupling and drive screw and insert the roll pin. Use a hammer and 1/8" punch to install.
10. Return to the instruction for the installation of the Drive Screw, step 4.

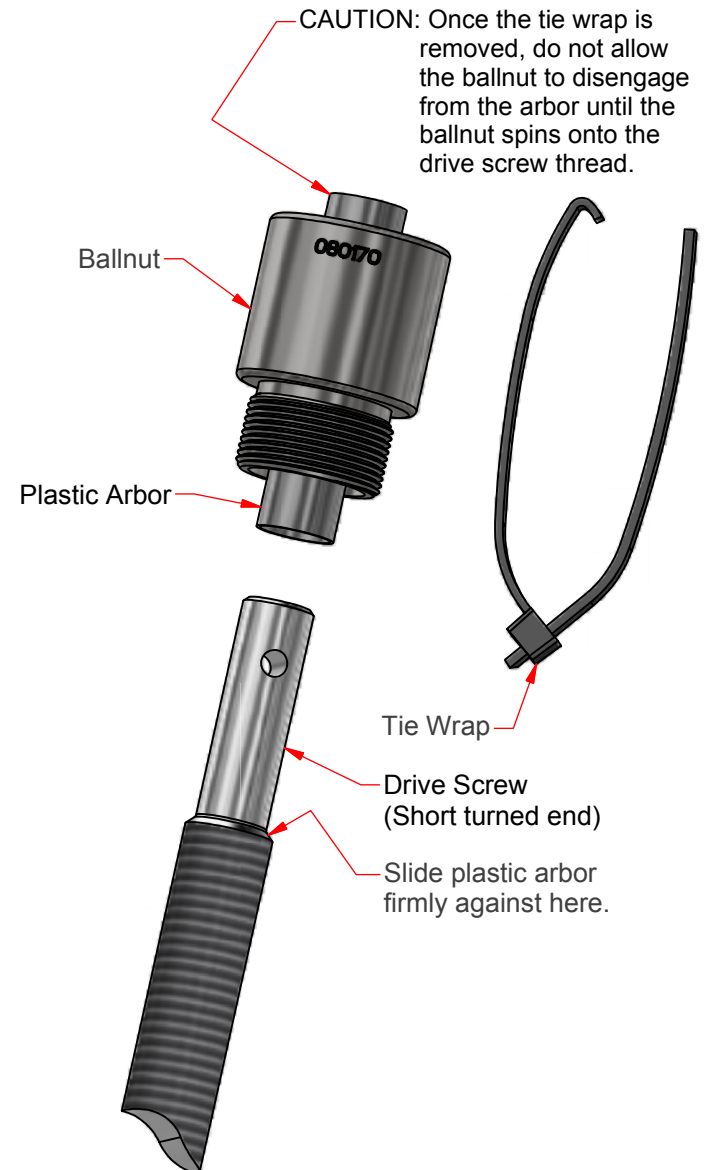
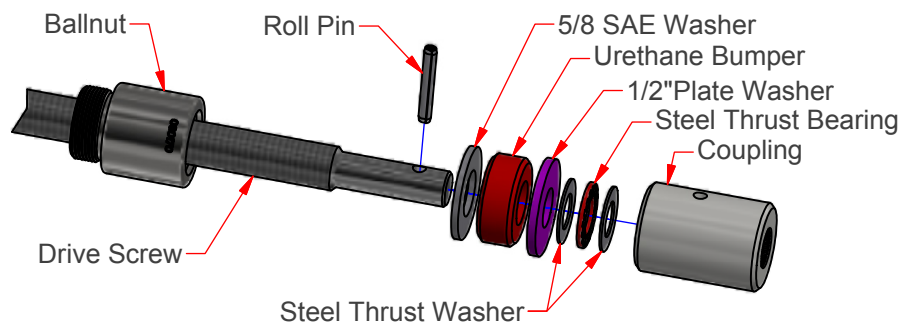

Provision has been made to adjust the retract height of the LV-7 PowerMate so that the Toeplate Loop can be stopped at a maximum height in the vehicle. This short range of adjustment is made to facilitate common height rolling pallets or carts without having to jog the height when loading.

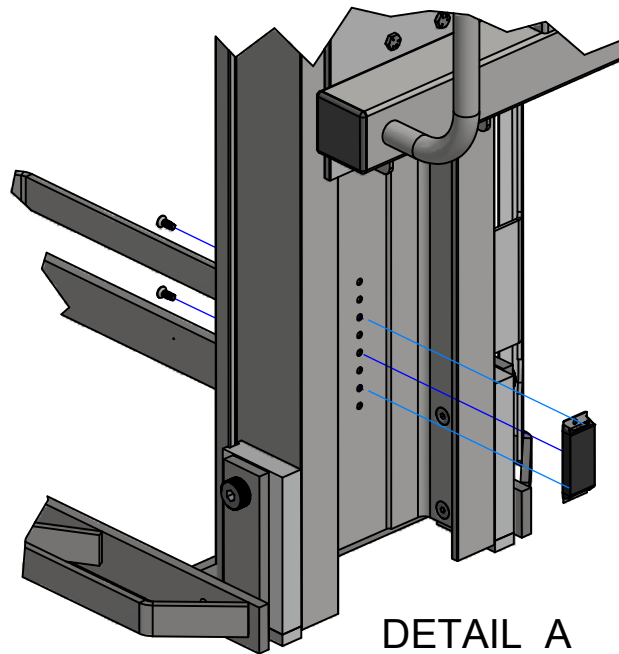

**DETAIL A**

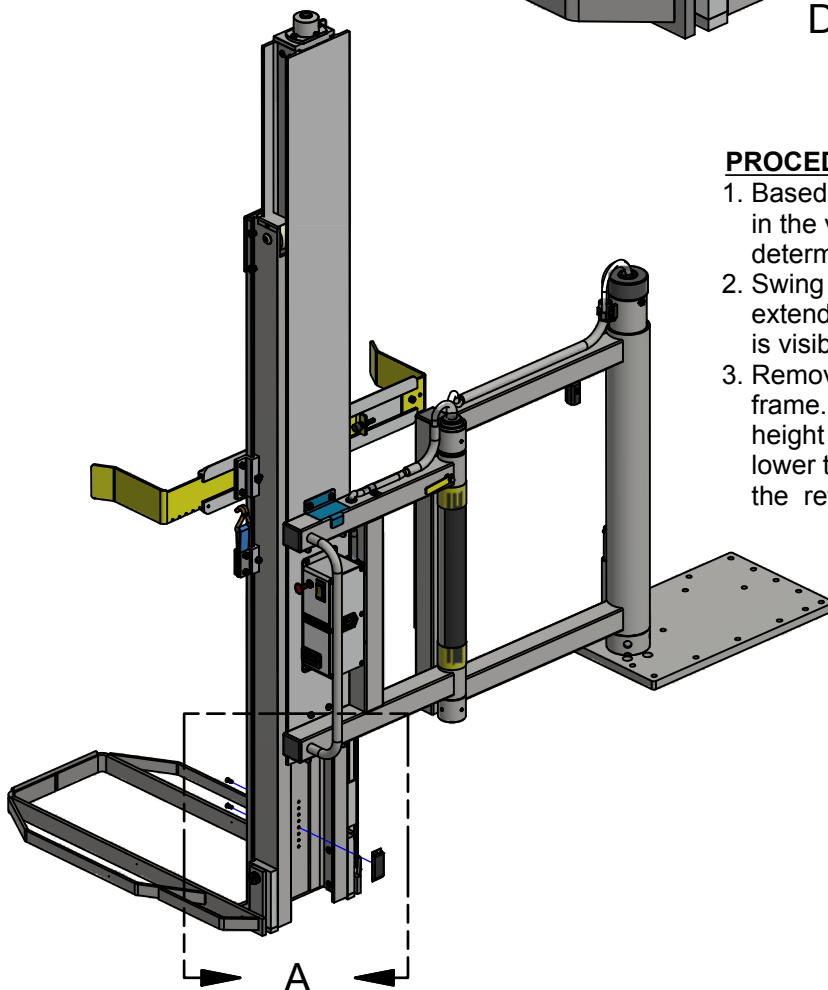

**PROCEDURE**

1. Based on the height of the Toeplate Loop above the floor in the vehicle when fully retracted (won't go up anymore), determine how much correction is desired for the height.
2. Swing the unit out of the vehicle to a lowering position and extend (lower) the outer frame until the rectangular magnet is visible.
3. Remove the 10-24NC Screws from the face of the outer frame. Raise or lower the magnet to the desired corrected height and re-install the screws. Raising the magnet will lower the retract height and lowering the magnet will raise the retract height.

**RETRACT STROKE ADJUSTMENT**

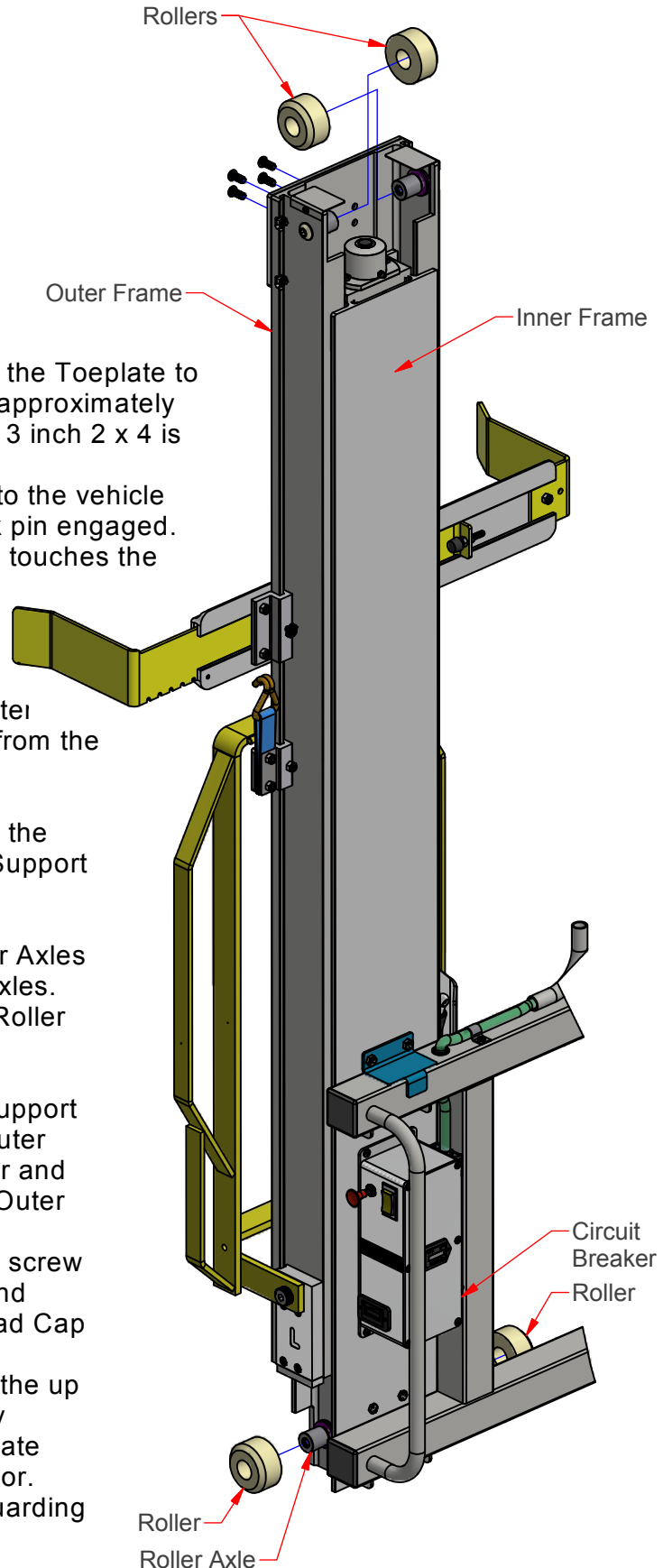
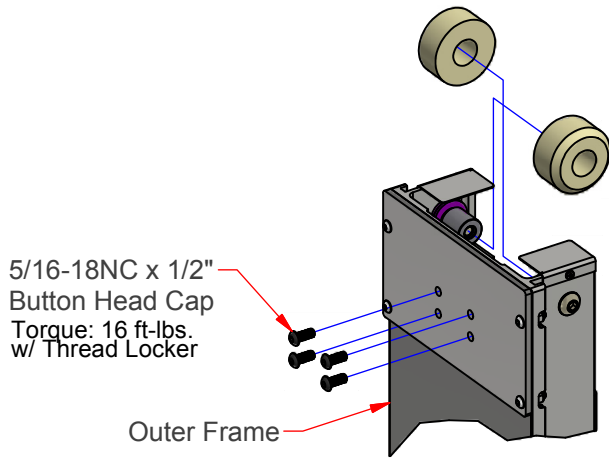

- STEP 1. Provide a support to be placed underneath the Toeplate to support the Outer Frame when it is raised approximately six inches higher than the vehicle floor. A 13 inch 2 x 4 is suitable.
- STEP 2. Swing the Outer Frame Arm 90 degrees into the vehicle leaving the Main Arm in place with the lock pin engaged. Extend the Lift Gate Unit until the Toeplate touches the vehicle floor. Move the Circuit Breaker Toggle Switch to the down position and depress the Power Disconnect Switch .
- STEP 3. Remove the four 5/16-18NCx1/2" Button Head Cap Screws at the top face of the Outer Frame. This dis-engages the Outer Frame from the Screw Drive Ballnut Bracket.
- STEP 4. Manually lift the Outer Frame approximately 6 inches until the Rollers, at the top and bottom, are completely exposed. Support the Outer Frame using the 13" wood stud between the floor and the Outer Frame.
- STEP 5. Remove the old Rollers and wipe the Roller Axles clean. Remove any nicks or burrs on the axles.
- STEP 6. Apply a light machine lubricant to the four Roller Axles and install the new Rollers. Wipe off excess lubricant.
- STEP 7. Supporting the Outer Frame, remove the support underneath the Outer Frame. Lower the Outer Frame to re-engage the Rollers in the Inner and Outer Frames. Continue to lower until the Outer Frame rests on the vehicle floor.
- STEP 8. Align the holes in the Outer Frame with the screw holes in the Screw Drive Ballnut Bracket and secure with the four 5/16-18NC Button Head Cap Screws.
- STEP 9. Move the Circuit Breaker Toggle Switch to the up position. Reconnect the electrical power by pulling the Power Disconnect Switch. Activate the unit to raise the Outer Frame off the floor. Test operation of the unit. Insure that all guarding is in place.

## **ROLLER REPLACEMENT**

**ASSEMBLY EXPLANATION**

Screws are inserted into Back Bar followed by installing the Sliding Guide. Screws are secured using a 5/32" allen key through the holes in the Sliding Guide.

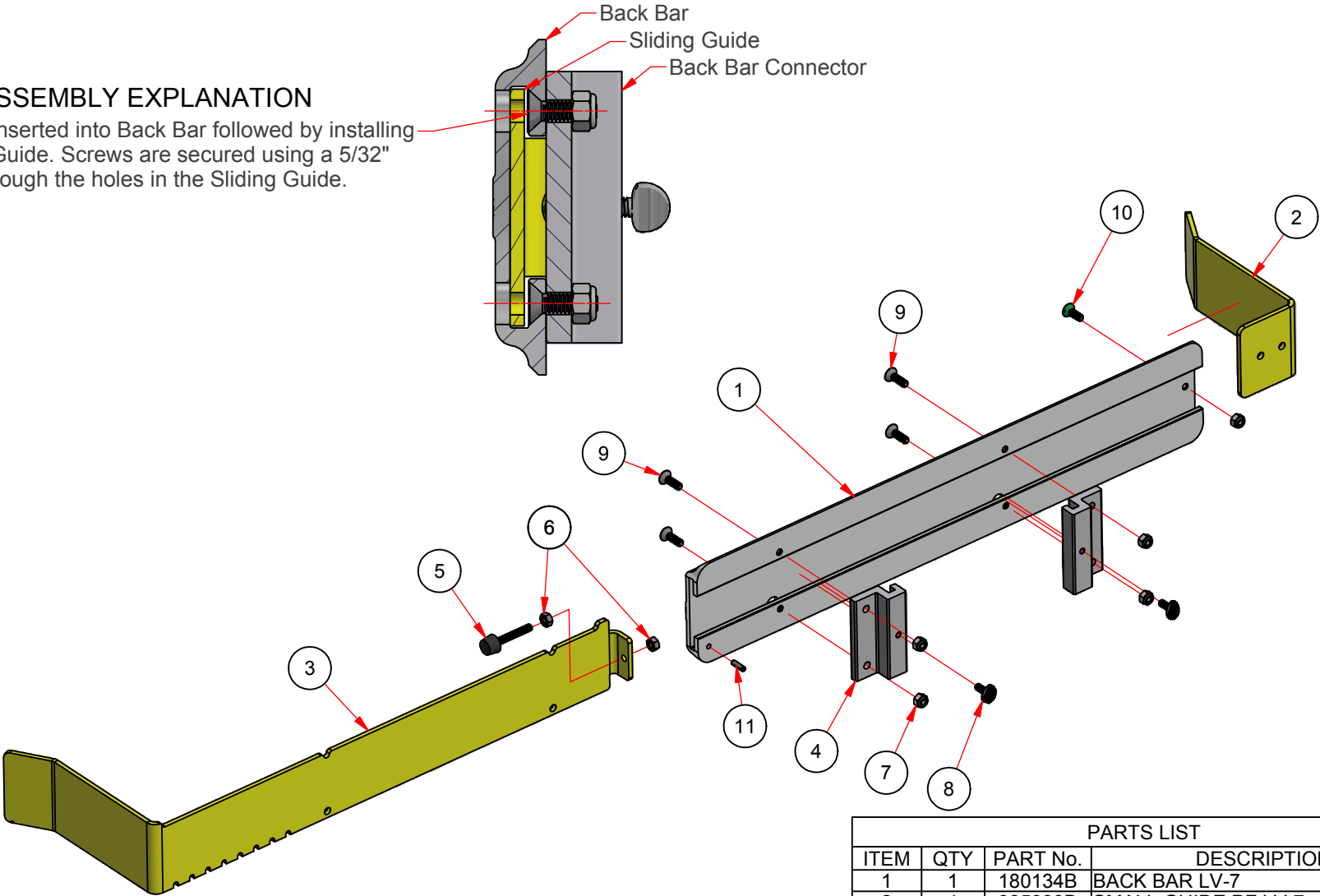

**RIGHTHAND BACK BAR**  
PN389336D

PARTS LIST			
ITEM	QTY	PART No.	DESCRIPTION
1	1	180134B	BACK BAR LV-7
2	1	385333B	SMALL GUIDE PF LV-7
3	1	385334C	SLIDING GUIDE PF LV-7
4	2	180136A	BACKBAR CONNECTOR LV-7
5	1	040941A	RUBBER STOP BOLT
6	2	050700A	NUT 1/4-20 HEX ZINC
7	5	050610A	NUT 1/4-20 RING LOCK ZINC
8	2	050583A	SCREW 1/4-20NC THUMB
9	4	050645A	BOLT 1/4-20 x 7/8 CS HEX
10	1	050560A	SCREW CS FLAT SLOT 1/4-20 x 3/4
11	1	081861A	ROLL PIN 3/16 DIA. x 5/8"

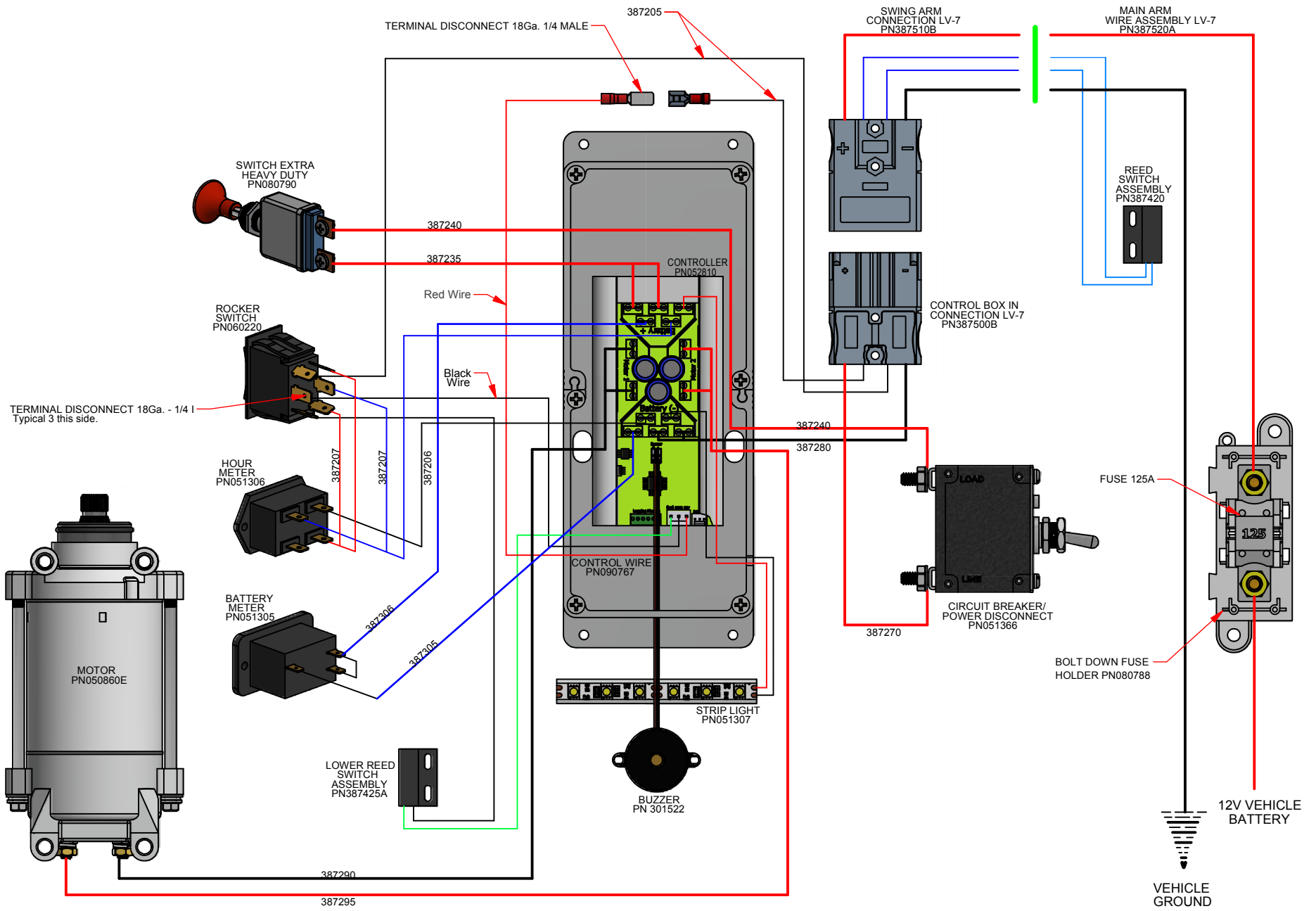

**LV-SERIES WIRING DIAGRAM**

## POWERMATE LV-SERIES ACTUATOR - MANUAL RETRACTION

If an event occurs that the Actuator will not operate, and the PowerMate Unit is in an extended position, the Actuator can be retracted using the 3/16" Hex Key provided.

Before proceeding, insure the Battery Disconnect Switch is in the disable (pushed in) position, and the Circuit Breaker Toggle is in the down position.

Remove the Plastic Plug from the top of the Actuator Brake Cap (press fit). Insert the 1/4-20NC Socket Head Cap Screw into the hole at the top of the Brake Cap, engaging the screw thread in the end of the Drive Screw. Insert the Hex Key into the Socket Head Cap Screw. Rotate the Hex Key clockwise until the Actuator is fully retracted.

Re-install the Plastic Plug, stow the Hex Key and Cap Screw, and determine the reason the Actuator is not functioning.

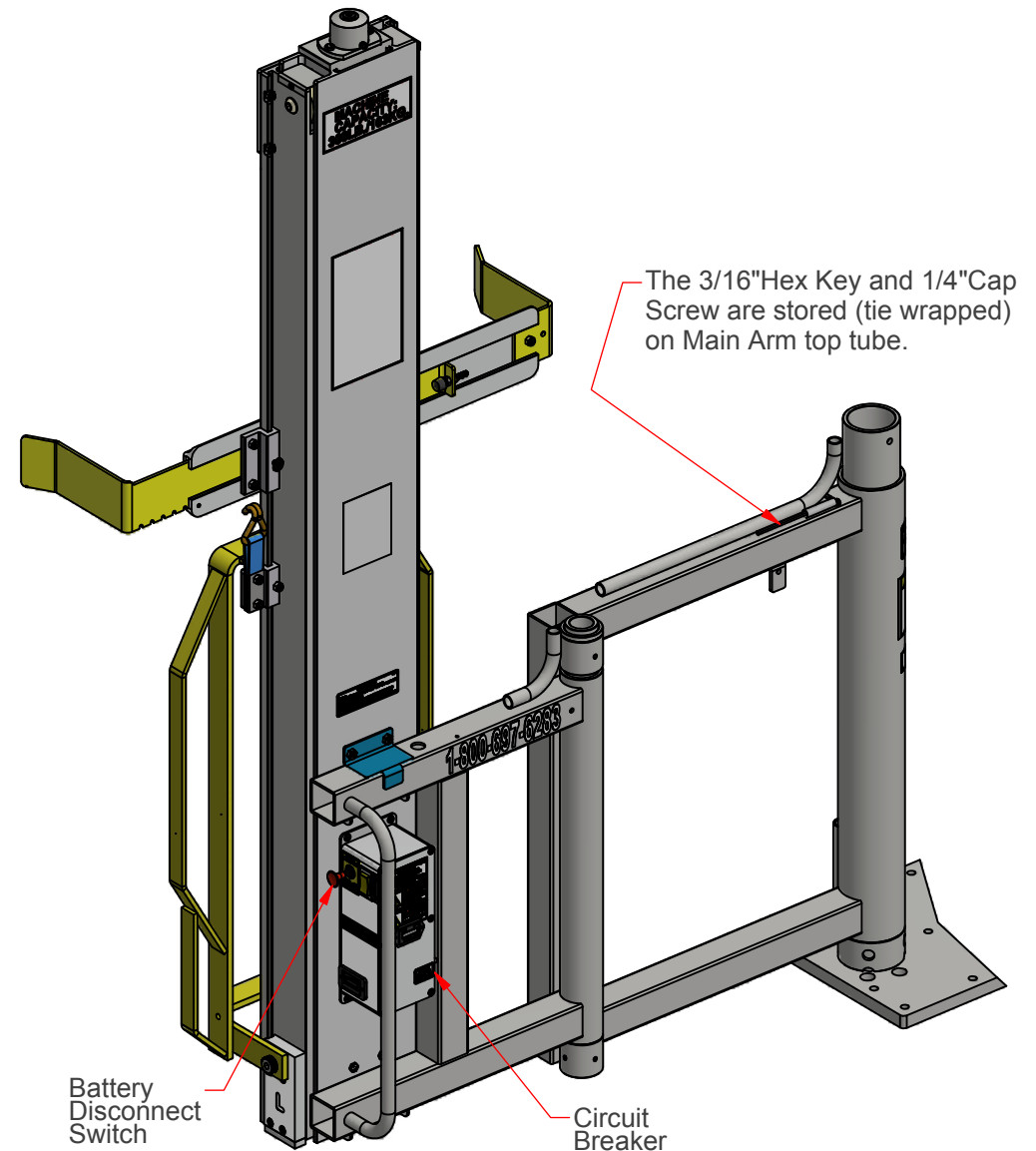
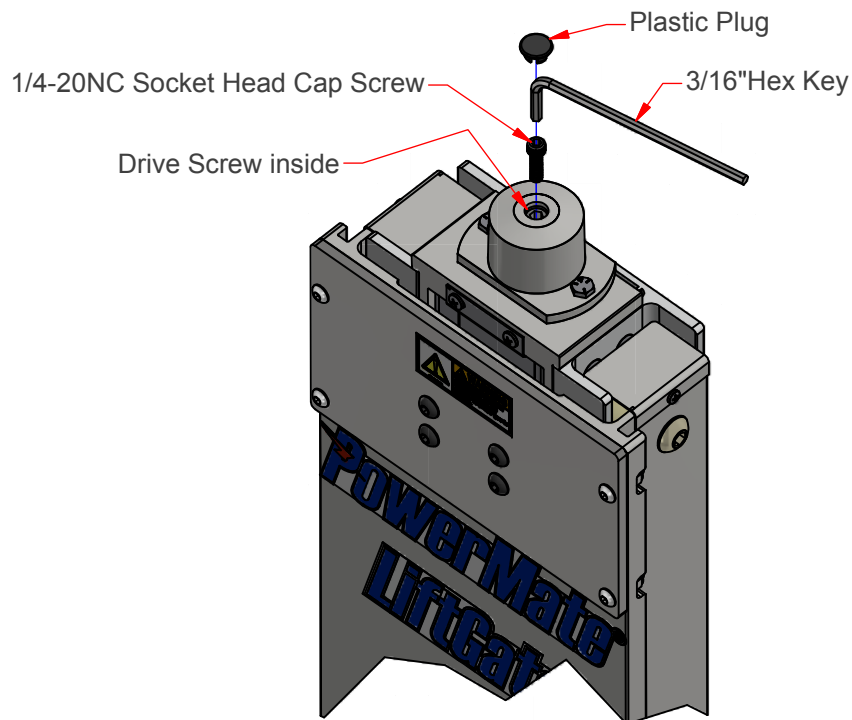

## LV-SERIES SPECIFICATIONS ANSI/CSA

<b>Model</b>	<b>LV-7 (TL)</b>
<b>Weight</b>	232 lbs.
<b>Height</b>	71.5"
<b>Width</b>	26.625"
<b>Back Bar Width</b>	29.375" Capacity
<b>Depth</b>	20.50"
<b>Ballscrew</b>	.625"
<b>Stroke Length</b>	48"
<b>Extension Speed</b>	5" Per Second (no load)
<b>Load Capacity</b>	360 lbs.

## LV-SERIES SPECIFICATIONS CE

<b>Model</b>	<b>LV-7 (TL)</b>
<b>Weight</b>	105 kgs.
<b>Height</b>	1.82m
<b>Width</b>	.676m
<b>Back Bar Width</b>	746mm Capacity
<b>Depth</b>	.521m
<b>Ballscrew</b>	15.88mm
<b>Stroke Length</b>	1.22m
<b>Extension Speed</b>	127mm per sec.
<b>Load Capacity</b>	163.3 kgs.

NOTE: Weights are approximate due to manufacturing tolerances. Data given for LV-Series PowerMates equipped with standard equipment.



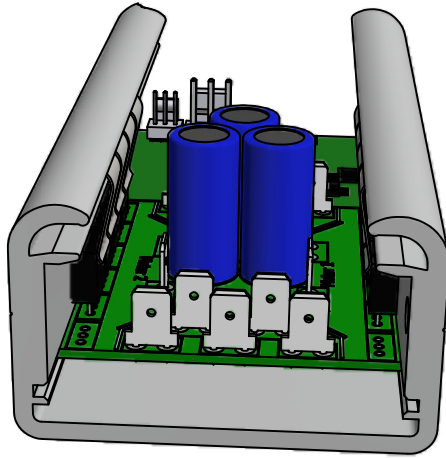

## STAIR CLIMBER SOLIDSTATE CONTROLLER

The Stair Climber Solid State Controller is a fully solid state Pulse Width Modulated (PWM) controller. Its advanced microprocessor based control implements a state-of-the-art power MOSFET motor drive. Advanced features provide improved functionality, smoother operation, reduced mechanical stress, and protects against abuse and system faults.

### ADVANTAGES

- Reduced peak current reduces power loss in batteries, motor, and cabling.
- Reduced peak current reduces battery stress, increased service life.
- Reduced peak torque reduces mechanical stress, increasing service life of the gear train and motor.
- Smooth operation "feel" by controlled acceleration and deceleration (motor voltage ramp-up and ramp-down) eliminating jerkiness.
- Automatically slows speed with heavy loads, improving control and safety.
- Overload protection shuts off if lift load is too heavy.
- Protects batteries by limiting minimum loaded voltage to 8.5 volts.
- Internal protections for many types of internal and external faults.
- Protects controller by inhibiting operation if battery voltage is too high.
- Detects battery+ or battery- short to frame and inhibits motor operation.
- Limits continuous operation to <30 seconds. Control wiring fault protection.
- Alerts to low or excess control heating (from over-use).
- Alerts to overload or excess continuous run time (control fault).
- Alerts to battery+ or battery- short to frame.
- Alerts to internal controller faults.
- Low standby power of less than 20mA.

### SPECIFICATIONS

Operating Voltage Range:	8.5V - 14.4V
Maximum Voltage:	16.0V (non-operating)
Over-voltage shut-off	15.5V
Motor Current Limit:	100 Amps (+10%, -5%)
Output Time Rating (@100 Amps):	1.5Min. Minimum (ambient & initial temp<25°C)
Continuous Current (Ambient<25°C)	65 Amps (75 Amps in Le-Series Unit)
Maximum Run without stop:	25 to 30 Seconds (software limited)
Input control current, Max.(@ 13V)	0.3 mA
Standby Current (@12.6V)	< 18mA
Buzzer or LED output:	5 Volts, maximum 15mA
Standby Time (25% charge remains)	40 days (start with 20 AH battery, fully charged)
Operating Temperature Range:	-25°C to 50°C
Storage Temperature Range:	-40°C to 85°C
Environmental:	Solid State Controller Unit is 100% RoHS compliant.

### FAULT ALERTS

Faults are indicated by a buzzer producing a series of beeps to indicate various faults as follows:

**One Beep** - Overload condition (too much weight on Unit) - **Reduce Load**  
 - Maximum run time (25-30sec.) exceeded - **Release and re-apply switch**

**Two Beeps** - Low Battery - **Recharge Battery**

**Three Beeps**- Battery+ or Battery- shorted to frame. **HALT USE AND RETURN FOR REPAIR**

-System Fault - **FAULTY UNIT -HALT USE AND RETURN FOR REPAIR**

**Four Beeps** - Overheating due to excessive use (many minutes) - **Allow five minutes to cool**

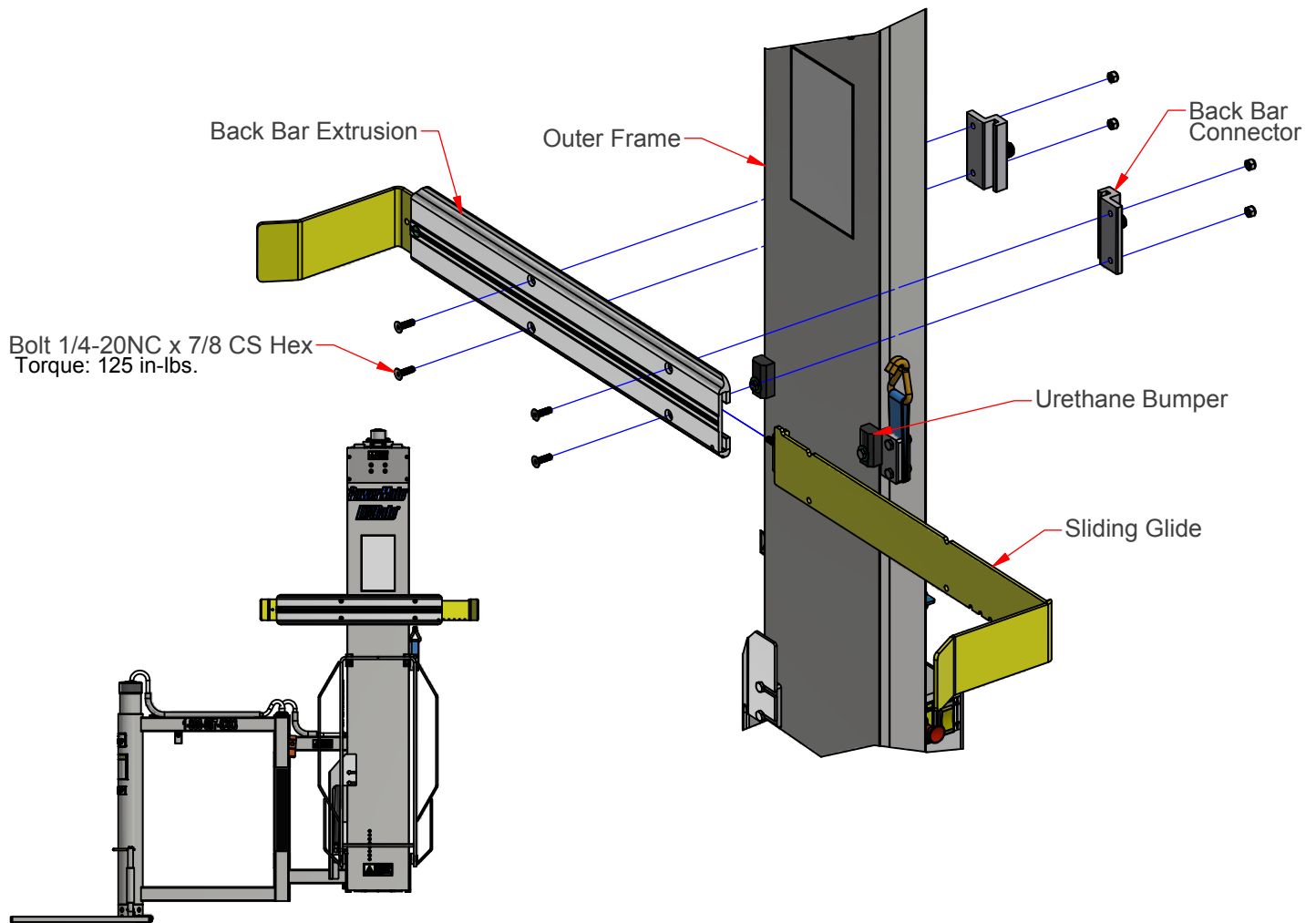

Step 1. Pass the 1/4-20NC CS Bolts through the large holes on the face of the Back Bar Extrusion and insert them into the smaller holes in the back of the extrusion. Install the Sliding Guide into the slot in the Back Bar Extrusion passing over the heads of the 1/4-20NC Bolts. Align the holes in the Sliding Guide with the Bolt heads to allow insertion of a 5/32" allen key.

Step 2. Place and hold the Back Bar Extrusion against the face of the Outer Frame Extrusion, resting on the urethane bumpers. Install a Back Bar Connector over the exposed bolt threads and apply the 1/4-20NC Nuts. Do not tighten. Repeat on opposite side.

Step 3. Slide the assembly up the Outer Frame extrusion to desired height. When in place, tighten the four 1/4-20NC Bolts and Nuts using the 5/32" allen key and 7/16" wrench.

Tools required: 5/32" Allen Key and 7/16" Wrench.

## BACK BAR INSTALLATION



# LIFT GATE Model LG-3

## FEATURES:

- Motor provides 100% of the lifting.
- Automatic braking system.
- Simple rocker switch activation.
- Articulated arm movement.
- Small footprint.
- Works from vehicle electric system.
- Load and unload in smaller space.
- Durable construction, low maintenance.

## BENEFITS:

- Reduces physical effort used to move heavy loads.
- Reduces the chance of personal injury.
- Lowers labor costs.
- Increases job efficiency and productivity.
- Improves degree of customer service.
- Flexible positioning.
- Provides increased utility, ie. larger/heavier loads in smaller vehicle.
- More useful space in vehicle.
- No charger to plug in.
- No ramping.
- Single person operation.



**PowerMate® LG-3 takes the strain out of moving:**

**HOME OXYGEN TANKS, SMALL PARCELS, BOXES OF PAPER, BOTTLED WATER, CERAMIC TILES, FIVE GALLON PAILS OF PAINT/CHEMICALS, ETC.**

**PowerMate® LG-3 SAVES...MONEY...LABOR...TIME...BACKS. ORDER NOW !!!**

L P INTERNATIONAL INC.  
151 Savannah Oaks Drive, Box 696  
Brantford, Ontario N3T 5P9

**www.powermate.info**





# LIFT GATE Model LG-6

## FEATURES:

- Motor provides 100% of the lifting.
- Automatic braking system.
- Simple rocker switch activation.
- Articulated arm movement.
- Small footprint.
- Works from vehicle electric system.
- Load and unload in smaller space.
- Durable construction, low maintenance.

## BENEFITS:

- Reduces physical effort used to move heavy loads.
- Reduces the chance of personal injury.
- Lowers labor costs.
- Increases job efficiency and productivity.
- Improves degree of customer service.
- Flexible positioning.
- Provides increased utility, ie. larger/heavier loads in smaller vehicle.
- More useful space in vehicle.
- No charger to plug in.
- No ramping.
- Single person operation.

**PowerMate® LG-6 takes the strain out of moving:**

**HOME OXYGEN TANKS, SMALL PARCELS, BOXES OF PAPER, BOTTLED WATER, CERAMIC TILES, FIVE GALLON PAILS OF PAINT/CHEMICALS, ETC.**



**PowerMate® LG-6 SAVES...MONEY...LABOR...TIME...BACKS. ORDER NOW !!!**

L P INTERNATIONAL INC.  
151 Savannah Oaks Drive, Box 696  
Brantford, Ontario N3T 5P9

[www.powermate.info](http://www.powermate.info)

8.02

PN 019940 Rev.A  
Eng. 06/ 15/ 15

## DECLARATION OF CONFORMITY

ORIGINAL LANGUAGE VERSION

Date:

Manufacturer: L P INTERNATIONAL INC.  
Box 696, 151 Savannah Oaks Dr  
Brantford ON CA N3T 5P9

declares that the apparatus:

**PowerMate® Model      Serial №**

⇒ conforms to the protection requirements of Council directive:

**2006/42/EC (Machinery Directive)  
2004/108/EC (Electromagnetic Compatibility Directive)**

on the approximation of the laws of the Member States relating to machinery directive and electromagnetic compatibility.

⇒ STANDARDS including Annex 1 of 2006/42/EC and 4 (Lifting)

**NAME                      L. Jeavons**

**TITLE                      General Manager**

**SIGNATURE**

## Warranty

Every **PowerMate**® Safety Moving System supplied by L P INTERNATIONAL INC. including accessories, with the exception of straps, is guaranteed against faulty workmanship and defective materials for a period of one year from date of purchase, when given normal use and maintenance in accordance with operation manual.

The above warranty for parts will apply only to the original purchaser.

L P INTERNATIONAL INC. do not hold themselves responsible for any damage caused by atmospheric or chemical influences nor defects due to unskilled operation, lack of maintenance and use of unprescribed lubricants. Neither do they accept responsibility for normal wear and tear and consequences therefrom. Warranty Service is available through your local authorized dealer or distributor. Warranty is void if serviced by unauthorized persons.

Machine Model \_\_\_\_\_ Serial No. \_\_\_\_\_



Manufactured By:  
**L P INTERNATIONAL INC.**

MAILING ADDRESS

P.O. BOX 696, 151 SAVANNAH OAKS DR.  
BRANTFORD, ONTARIO, CANADA  
N3T 5P9

USA MAILING ADDRESS:  
P.O. BOX 1132  
LEWISTON, N.Y., 14092-8132

PHONE: (519) 759-3292  
1-800-697-6283  
FAX: (519) 759-3298

## **DAILY MAINTENANCE SCHEDULE**

- Inspect unit frames for structural damage.
- Inspect frame hinge points. Apply lubricant (non-flammable) if required.
- Inspect all bolts and fasteners are in place and secure.
- Inspect the circuit breaker toggle switch, power disconnect, and up/down rocker switch for condition and operation. Make sure the wiring is secure.
- Cycle the unit testing for operation, direction and smoothness.
- Check that the toeplate is secure and not bent.
- Observe the roller operation in the outer frame rails. Oil rollers as required.
- Ensure the operation manual is readily available for reference.

**FOR PARTS AND SERVICE CONTACT:**

**1-800-697-Mate**

